

ATN ODIN

THERMAL MULTI-PURPOSE SYSTEM



OPERATOR'S MANUAL (ODIN) REVISION 1 – MARCH 2013

operator's manual

Important Export Restrictions! Commodities, products, technologies and services contained in this manual are subject to one or more of the export control laws and regulations of the U.S. Government and they fall under the control jurisdiction of either the US Department of State or the US BIS-Department of Commerce. It is unlawful and strictly prohibited to export, or attempt to export or otherwise transfer or sell any hardware or technical data or furnish any service to any foreign person, whether abroad or in the United States, for which a license or written approval of the U.S. Government is required, without first obtaining the required license or written approval from the Department of the U.S. Government having jurisdiction. Diversion contrary to U.S. law is prohibited.



**AMERICAN
TECHNOLOGIES
NETWORK
CORP.**

**Register your product warranty online at
www.atncorp.com/warranty**

Manual (Odin) Revision 1 - MARCH, 2013

The information in this manual furnished for information use only, is subject to change without notice, is not to be construed as a commitment by ATN Corp. ATN Corp. assumes no responsibility or liability for any errors or inaccuracies that may appear in this book.

© 2013 ATN Corp. All right reserved.

SAFETY SUMMARY

STUDY CAREFULLY THIS MANUAL BEFORE TURNING ON AND OPERATING THIS PRODUCT.

CAUTIONS

The ATN Odin thermal multi-purpose system are precision optical-electronic instruments and requires careful handling. To provide safe use of the systems the following instructions should be observed:

- Do not dismantle the device.
- Keep the device clean; protect it from moisture, sharp temperature drops and shocks.
- Be careful not to touch the glass surfaces. If you put fingerprints on, or contaminate the glass surfaces, use only clean and soft materials to clean it.
- Do not leave the device in on position during stops in operation.
- Remove the battery from the device for the period of storage.

CAUTION:

THIS PRODUCT CONTAINS NATURAL RUBBER LATEX WHICH MAY CAUSE ALLERGIC REACTIONS

WARNING

Do not permanently attach the device to dynamic-mount applications that continuously transmit vibration (such as on vehicles or heavy machinery).

WARNING

Do not point the monocular directly at any high-intensity objects that you must not view with your eyes (such as the sun or a weld- ing arc). If you do, you will damage the camera.

WARNING

Operating Odin outside of its specified operating temperature range or voltage range can cause permanent damage and will void the warranty.

WARNING

Use the power switch to turn the camera off before you remove power (remove battery).

WARNING

Do not use any battery other than a CR-123A lithium battery. DO NOT use any battery(ies) providing a (combined) voltage greater than 3.0 volts.

WARNING

Do not replace battery in a possibly explosive environment, such as a gas station (or any place where you must turn off your vehicle engine). If you do, sparks can cause an explosion.

WARNING

Remove the battery before you store the camera for extended periods (2 weeks or more).

WARNING

Do not carry battery in pockets containing metal objects such as coins, keys, etc. Metal objects can cause the battery to short circuit and become very hot. In the case of lithium batteries, a short circuit could cause them to explode.

WARNING

Observe battery manufacturer's guidelines for safe handling and proper disposal of batteries.

NOTE

Please be aware that the most common problem that first time users of Thermal products encounter is improper utilization of Calibrate/NUC function. The first step before using the product should be to properly calibrate the device. To do this please turn the unit on, close the objective lens with the lens cap and press the Calibrate/NUC function either as described in 3.2.2.3 or by holding down both the UP and DOWN buttons at the same time. Please carefully read 3.2.2.3 as to additional information on Calibration/NUC function.

EQUIPMENT LIMITATIONS

- The Odin detector spectral band (7 to 14 μm) provides a better penetration through smoke, smog, dust, water vapor etc.
- Infrared radiation does not travel through glass and therefore the monocular does not sense objects if they are behind a glass window.

TABLE OF CONTENTS

	pg.
CHAPTER 1. INTRODUCTION	1-1
1.1 General Information	1-2
1.1.1. Scope	1-2
1.1.2. Reports	1-2
1.1.3. Storage	1-2
1.1.4. Warranty Information	1-2
1.2. Equipment Description.	1-5
1.2.1. Equipment characteristics, capabilities and features	1-5
1.2.2. Location and description of major components	1-6
1.2.3. Specifications	1-9
1.2.4. Mechanical Functions	1-11
1.2.5. Optical Functions	1-11
1.2.6. Electrical Function	1-12
CHAPTER 2. ASSEMBLY AND PREPARATION.	2-1
2.1. Preparation	2-2
2.1.1. Preparation for use	2-2
2.1.2. Installation of eyecup	2-3
2.1.3. Installation of demist shield.	2-3
2.1.4. Installation and adjustment of headmount	2-4
2.1.5. Installation of headmount/helmet mount adapter ..	2-5
2.1.6. Installation of helmet mount to helmet.	2-6
2.1.7. Installation of headmount with protective mask	2-8
2.1.8. Installation of weapon mount	2-9
CHAPTER 3. OPERATION.	3-1
3.1. General Information	3-2
3.1.1. General	3-2
3.1.2. Controls and Indication	3-2
3.2. Operating procedure	3-4
3.2.1. Turning On	3-4
3.2.2. Menu sets	3-4

3.2.3. Hand-held operation	3-11
3.2.4. Head mounted operation	3-11
3.2.5. Helmet mounted operation	3-13
3.2.6. Weapon mounted operation	3-15
3.2.7. Preparation for storage	3-16
CHAPTER 4. MAINTENANCE INSTRUCTIONS.	4-1
4.1. Lubrication Instructions.	4-2
4.2. Troubleshooting procedures	4-2
4.2.1. Troubleshooting	4-2
4.3. Operator's Maintenance Procedures	4-5
4.3.1. Cleaning the scope	4-5
4.3.2. Headmount Maintenance	4-5
4.3.3. Neck cord maintenance	4-7

HOW TO USE THIS MANUAL

- **Usage**

You must familiarize yourself with the entire manual before operating the equipment. Read and follow all warning notices.

- **Manual Overview**

The table of contents includes the paragraph number, paragraph title, and page number.

CHAPTER 1

INTRODUCTION

1.1 GENERAL INFORMATION

1.1.1. SCOPE

This manual contains instructions for use in operating and maintaining the ATN Odin thermal multi-purpose systems. Throughout this manual, the ATN Odin will be referred to as the scope or Odin.

1.1.2. REPORTS

Reports from the user on recommendations for improvements are encouraged. Send reports to the address below.

American Technologies Network Corp.
1341 San Mateo Avenue
South San Francisco, CA 94080
(800) 910-2862
(650) 989-5100
(650) 875-0129 fax
info@atncorp.com
www.atncorp.com

1.1.3. STORAGE

Storage of Odin should be done in the factory packing and after a thorough PMCS as outlined in Section 4.1. of this manual. This will ensure the scope remains in mission ready condition during storage. Battery should be stored separately from the scope.

The scope should not be placed on the floor, in any area exposed to high temperatures or direct sunlight. Presence of acid and alkaline vapor, as well as of other aggressive admixtures in the air is unacceptable.

1.1.4. WARRANTY INFORMATION

ONE YEAR PRODUCT WARRANTY

This product is guaranteed to be free from manufacturing defects in material and workmanship under normal use for a period of 1 (one) years from the date of purchase. In the event a defect that is covered by the foregoing warranty occurs during the applicable period stated above, ATN, at its option, will either repair or replace the product, and such action on the part of ATN shall be the full extent of ATN's liability, and the Customer's sole and exclusive remedy.

This warranty does not cover a product (a) used in other than its normal and customary manner; (b) subjected to misuse; (c) subjected to alterations, modifications or repairs by the Customer or by any party other than ATN without prior written consent of ATN; (d) special order or "close-out" merchandise or merchandise sold "as-is" by either ATN or the ATN dealer; or (e) merchandise that has been discontinued by the manufacturer and either parts or replacement units are not available due to reasons beyond the control of ATN. ATN shall not be responsible for any defects or damage that in ATN's opinion is a result from the mishandling, abuse, misuse, improper storage or improper operation, including use in conjunction with equipment which is electrically or mechanically incompatible with or of inferior quality to the product, as well as failure to maintain the environmental conditions specified by the manufacturer. This warranty is extended only to the original purchaser. Any breach of this warranty shall be waived unless the customer notifies ATN at the address noted below within the applicable warranty period.

The customer understands and agrees that except for the foregoing warranty, no other warranties written or oral, statutory, expressed or implied, including any implied warranty of merchantability or fitness for a particular purpose, shall apply to the product. All such implied warranties are hereby and expressly disclaimed.

LIMITATION OF LIABILITY

ATN will not be liable for any claims, actions, suits, proceedings, costs, expenses, damages or liabilities arising out of the use of this product. Operation and use of the product are the sole responsibility of the Customer. ATN's sole undertaking is limited to providing the products and services outlined herein in accordance with the terms and conditions of this Agreement. The provision of products sold and services performed by ATN to the Customer shall not be interpreted, construed, or regarded, either expressly or implied, as being for the benefit of or creating any obligation toward any third party of legal entity outside ATN and the Customer; ATN's obligations under this Agreement extend solely to the Customer. **ATN's liability hereunder for damages, regardless of the form or action, shall not exceed the fees or other charges paid to ATN by the customer or customer's dealer. ATN shall not, in any event, be liable for special, indirect, incidental, or consequential damages, including, but not limited to, lost income, lost revenue, or lost profit, whether such damages were foreseeable or not at the time of purchase, and whether or not such damages arise out of a breach of warranty, a breach of agreement, negligence, strict liability or any other theory of liability.**

PRODUCT WARRANTY REGISTRATION

In order to validate the warranty on your product, ATN must receive a completed Product Warranty Registration Card for each unit or complete warranty registration on our website at www.atncorp.com. Please complete the included form and immediately mail it to our Service Center: ATN Corporation, 1341 San Mateo Avenue, South San Francisco, CA 94080.

OBTAINING WARRANTY SERVICE

To obtain warranty service on your unit, End-user must notify ATN service department by calling **800-910-2862** or **650-989-5100** or via e-mail **service@atncorp.com** to receive a Return Merchandise Authorization number (RMA). When returning please take or send the product, postage paid, with a copy of your sales receipt to our service center, ATN Corporation at the address noted above. All merchandise must be fully insured with the correct postage; ATN will not be responsible for improper postage or, missing or damaged merchandise during shipment. When sending product back, please clearly mark the RMA# on the outside of the shipping box. Please include a letter that indicates your RMA#, Name, Return Address, reason for service return, Contact information such as valid telephone numbers and/or e-mail address and proof of purchases that will help us to establish the valid start date of the warranty. **Product merchandise returns that do not have an RMA listed may be refused or a significant delay in processing may occur.** Estimated Warranty service time is 10-20 business days. End-user/customer is responsible for postage to ATN for warranty service. ATN will cover return postage/shipping after warranty repair to end-user/customer only if product is covered by aforementioned warranty. ATN will return product after warranty service by domestic UPS ground and/or domestic mail. Any other requested, required or international shipping method the postage/shipping fee will be the responsibility of the end-user/customer.

1.2 EQUIPMENT DESCRIPTION

1.2.1. EQUIPMENT CHARACTERISTICS, CAPABILITIES AND FEATURES

The Odin Series is one of the smallest Thermal Imaging Monocular Systems today. It features extremely small size and low weight because of its advanced construction and characteristics using the latest technologies in high grade polymers to make a Mil. Spec, system that is identical in size, weight and shape to a AN/PVS-14.

The Odin series is a multi-purpose system using the latest in miniature thermal sensor technology combined with an advanced OLED Display to provide a superior stable image in a compact and rugged package. The system also includes an array of features that help the user to enhance the sight to meet all of their requirements.

The Odin system is designed for hand held, head mounted and weapon mounted operations. It uses most of the same accessories as the AN/PVS-14 Night Vision Monocular System.

The Odin is one of the most capable thermal monocular systems on the market.

The Odin-W Series has the ability to be rail mounted to a light caliber weapon such as a M16 or M4 using the accessory weapon rail interface adapter.

As with the standard Odin series has the With the ability to use most accessories for the AN/PVS-14 with the added benefit to be weapon mounted as well. The Odin-W is user friendly and easy to learn to use. The system design has been proven effective and reliable as well as functional. The Odin-W is a perfect complement to any user of night vision monocular systems.

1.2.2. LOCATION AND DESCRIPTION OF MAJOR COMPONENTS

Included and optional items are shown in Figure 1.1. The major components are the headmount, helmet mount, monocular, carrying case, and the shipping and storage case.

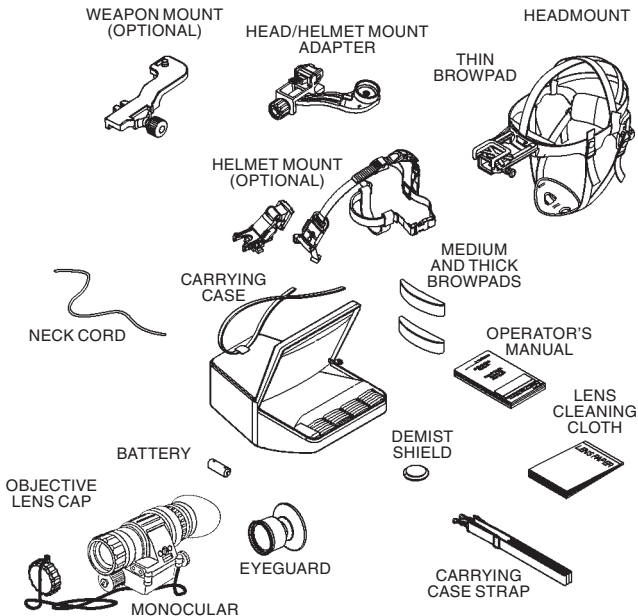

FIGURE 1.1. COMPONENTS OF ODIN

a. Monocular

The monocular (see Figure 1.2.) consists of various components such as an objective lens, a thermal core (not shown), an eyepiece lens and a battery cap.

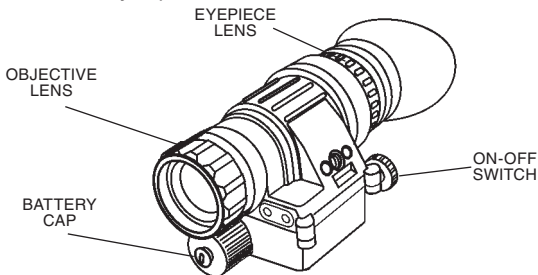

FIGURE 1.2. MULTI-PURPOSE THERMAL SYSTEM

The monocular also uses the accessories listed below:

Demist Shield – The demist shield (Figure 1.1.) is used to prevent the eyepiece lenses from becoming fogged.

Sacrificial Window – Please note the PVS14 sacrificial window will not work with the Odin. Do not attempt to use will not get an image.

b. Headmount

The headmount (Figure 1.1.) secures the monocular to the operator's head for night viewing and provides freehand support for use with a weapon, protective mask or other purposes. It is adjustable and cushioned. The thin browpad used for large heads, comes attached to the headmount; the thick and medium browpads, used for smaller heads are stored in the carrying case.

c. Helmet Mount

This item (Figure 1.1.), secures the monocular to the Personal Armor System Ground Troops (PASGT) helmet allowing freehand support for use with a weapon, protective mask and/or other purposes. The new helmet mount is made of a ruggedized metal. The old one is made of plastic.

d. Headmount/Helmet Mount Adapter

This item (Figure 1.1.) is attached to the monocular to allow its use with the headmount or helmet mount. It allows mounting in front of the left or right eye.

e. Weapon Mount

The weapon mount (Figure 1.1.) adapts the monocular to the receiver rail as configured for the modular weapon system kit.

f. Carrying Case

The carrying case (Figure 1.1.) is provided for transportation and protection of the monocular, headmount, battery and accessories. Two slide keepers are provided for belt attachment and three D-rings for shoulder and leg strap attachment. A carrying case strap is also provided which can be attached to the two D-rings on the back of the carrying case.

1.2.3. SPECIFICATIONS

The following tables provide information pertaining to the operational, electrical, mechanical, optical and environmental characteristics for the monocular.

Table 1-1. Specifications

ITEM	ODIN-31C ODIN-31CW	ODIN-31D ODIN-31DW	ODIN-32C ODIN-32CW	ODIN-32D ODIN-32DW	ODIN-6WB ODIN-6WBW	ODIN-61B ODIN-61BW
Sensor (micro-bolometer)	320 x 240 px					
Type	Uncooled					
Material	Vanadium oxide (VOx)					
Frame Rate	30 Hz	60 Hz	30 Hz	60 Hz	30 Hz	30 Hz
Pixel Size	17 mm		35 mm		17 mm	35 mm
Spectral Response	7-14 μ m					
Pixel Size	17 μ m					
Optical Magnification	1x		2x		0.5x	
E-Zoom	2x, 4x		4x, 8x		1x, 2x, 4x	
FOV	24° x 18°		15° x 11°		48° x 36°	
Focus Range	0.25 m to infinity					
Diopter Adjustment	-6 to +4					
Eye Relief	27 mm					

ITEM	ODIN-31C ODIN-31CW		ODIN-31D ODIN-31DW		ODIN-32C ODIN-32CW		ODIN-32D ODIN-32DW		ODIN-6WB ODIN-6WBW		ODIN-61B ODIN-61BW	
	Human Detection	500 m		500 m		750 m		750 m		500 m		750 m
Human Recognition	225 m		225 m		300 m		300 m		225 m		300 m	
Human Identification	135 m		135 m		180 m		180 m		135 m		180 m	
Vehicle Detection	1100 m		1100 m		1650 m		1650 m		550 m		1650 m	
Vehicle Recognition	495 m		495 m		660 m		660 m		495 m		660 m	
Vehicle Identification	300 m		300 m		400 m		400 m		300 m		400 m	
Multiple Reticles to Choose From	ODIN-31CW only		ODIN-31DW only		ODIN-32CW only		ODIN-32DW only		ODIN-6WBW only		ODIN-61BW only	
	800 x 600 px											
Image Size (output resolution)	800 x 600 px											
Polarity control	White hot / Black hot / Multiple Color Modes											
Start up time	<4 s											
Waterproof	Waterproof / Dustproof											
Battery type	1 x 3V, CR123A Lithium battery type											
Battery Life	>2 hrs											
Weight	0.77 lb / 0.35 kg											
Dimensions	3.40" x 2.20" x 1.95" / 87 mm x 56 mm x 50 mm											

* ATN reserves the right to change the above specifications at any time without notice

1.2.4. MECHANICAL FUNCTION

The mechanical adjustments of the Odin sights allow for physical differences between individual operators using the system. The scope functions include the ON-OFF switch, UP button, ENTER button, DOWN button, video-out, eyepiece diopter adjustment ring, battery compartment cover, mounting thread. The mechanical controls are identified in Figure 1.3.

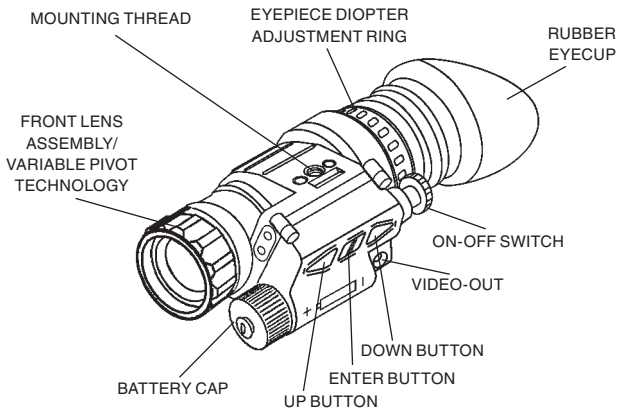

FIGURE 1.3. MECHANICAL CONTROLS

1.2.5. OPTICAL FUNCTIONS

The optical functions include an objective lens, thermal imaging detector and eyepiece. Infrared energy is emitted proportionally to the temperature of an object. The warmer the object, the more energy it emits. The infrared energy from the objects is focused by the optics, onto an infrared detector. The information from infrared detector is passed to electronics for image processing. The signal processing circuitry translates the infrared detector data into an image that can be viewed on the built-in OLED display. The image is observed through an eyepiece by operator.

1.2.6. ELECTRICAL FUNCTION

The electronic circuit is powered by replaceable battery – one 3 V Lithium battery (CR123A type battery).

Power from the battery is supplied to the components through the OFF-ON switch.

CHAPTER 2

ASSEMBLY AND PREPARATION

2.1. PREPARATIONS

2.1.1. PREPARATION FOR USE

This chapter contains the information necessary to prepare the scope for operation. This includes unpacking, examination for damage, and battery installation.

A. UNPACKING

The following steps must be accomplished prior to each mission where the sight is used.

1. Open carrying case, remove the scope and check contents for completeness.
2. Inspect the scope for obvious evidence of damage to optical surfaces, body, eyecups, operation buttons, etc. Ensure that all optical surfaces are clean and ready for use. Clean with lens paper.

B. ATTACHMENT OF NECK LANYARD

To prevent damage due to dropping the scope, use the neck lanyard included with your equipment.

C. INSTALLATION OF BATTERY

WARNING

The lithium battery contains sulphur dioxide gas under pressure.

Do not heat, puncture, disassemble, short circuit, attempt to recharge or otherwise tamper with the batteries.

Turn off equipment if battery compartment becomes unduly hot. If possible, wait until the batteries have cooled before removing them.

If you inhale sulphur dioxide, seek medical attention.

The Odin will operate with one CR123A Lithium battery type.

CAUTION

Make certain the operation switch is in the OFF position before installing batteries.

Install CR123A Lithium batteries as follows.

1. Remove the battery cap by turning it counterclockwise.
2. Check to ensure the o-ring is present. If not, replace it.
3. Observe polarity, as indicated on the outside of the battery compartment and insert one 3.0 Volt CR123A Lithium battery into the battery compartment, minus (-) end first (Figure 2.1.).
4. Replace battery cap by pushing and turning it clockwise. Tighten it firmly to ensure a watertight seal.

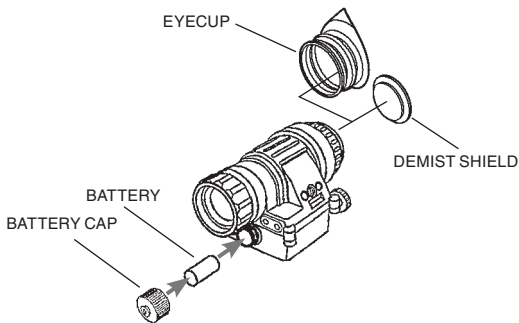

FIGURE 2.1. BATTERY AND EYECUP INSTALLATION

2.1.2. INSTALLATION OF EYECUP

Perform the following procedure to install eyecup or eyeguard onto the monocular. Refer to Figure 2.1.

- (1) Carefully press the eyecup or eyeguard over the end of the eyepiece lens.
- (2) Rotate the eyecup or eyeguard into proper viewing position. Adjust for best fit. The eyecup must seal around your eye and prevent the green glow from escaping.

2.1.3. INSTALLATION OF DEMIST SHIELD

Perform the following procedures to install the demist shield on the eyepiece lens. Refer to Figure 2.1.

CAUTION

If the demist shield needs to be cleaned, refer to paragraph 4.3.1. for cleaning. If the demist shield is wiped while wet or with wet lens paper, you will damage the coating.

NOTE

If inclement operating conditions are expected to exist (e. g. significant temperature change and high humidity), install demist shield to minimize eyepiece lens fog prior to execution of mission.

- (1) Carefully remove the eyecup.
- (2) Carefully press the demist shield onto the eyepiece. Be careful not to smudge the eyepiece lens or demist shield.
- (3) Replace the eyecup (see paragraph 2.1.2.).

2.1.4. INSTALLATION AND ADJUSTMENT OF HEADMOUNT

Perform the following procedures for donning the headmount.

NOTE

Do not don the headmount while the monocular is attached.

- (1) Prior to donning the headmount, loosen the four ends of the chinstrap approximately two inches from the sliding bar buckles (Figure 2.4.).
- (2) Snap the front and rear snaps (Figure 2.2.) in place.

NOTE

If the headmount is too loose, remove the attached thin browpad (Figure 2.2.) and replace with either the medium or thick browpad stored in the carrying case. Refer to paragraph for removal and replacement of the browpads.

- (3) With both hands grasp the neck pad (Figure 2.2.) and pull the harness over your head and the neck pad down to the back of your neck.
- (4) Holding the chin cup in position on chin, adjust both sides of the chinstrap until you feel light pressure against your chin. (DO NOT TIGHTEN.)
- (5) Maintain the position of the chin cup and remove any slack from the chinstrap. (DO NOT TIGHTEN.)

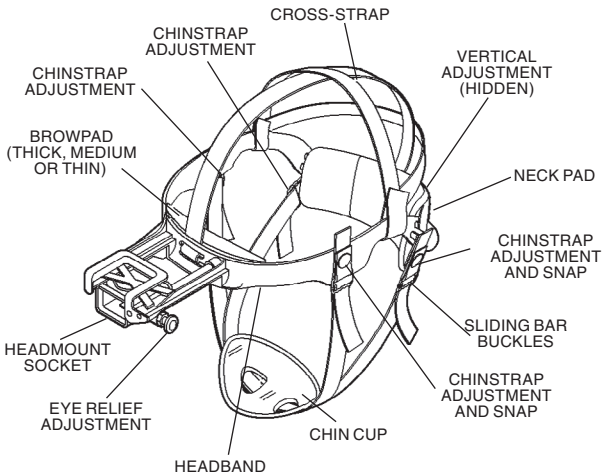

FIGURE 2.2. ODIN HEADMOUNT ADJUSTMENTS

- (6) Ensure that the cross-strap is not twisted and remove slack by adjusting the vertical adjustment at the neck pad.
- (7) Adjust chinstrap and vertical adjustment until the chin cup and headband are in a comfortable but firm position.

NOTE

After installing the monocular, minor strap adjustments may be necessary to achieve comfort.

- (8) Install the headmount/helmet mount adapter (refer to paragraph 2.1.5.).
- (9) Refer to paragraph 3.2.5. for operating procedures.

2.1.5. INSTALLATION OF HEADMOUNT/HELMET MOUNT ADAPTER

Install the headmount/helmet mount adapter (Figure 1.1.) into the monocular by aligning thumbscrew to hole and tightening as shown in Figure 2.3. There is an alignment boss on the headmount/helmet

mount adapter that fits into a groove on the monocular. Make sure the boss on the adapter fits into the groove on the monocular.

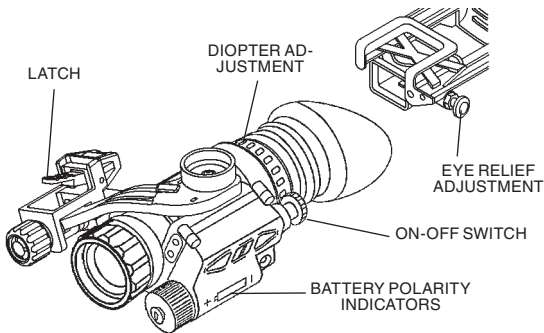

FIGURE 2.3. HEADMOUNT/HELMET MOUNT ADAPTER INSTALLATION

2.1.6. INSTALLATION OF HELMET MOUNT TO HELMET

- (1) Remove the helmet mount from the carrying case. Refer to Figure 2.4. for helmet mount features.
- (2) Press the release (Figure 2.5.) to remove the mount from the helmet mount bracket.
- (3) Make sure the strap is laced onto the helmet mount bracket as shown in Figure 2.4.
- (4) With catch (see Figure 2.4.) in forward most position, place the strap over the top of the helmet center (see Figure 2.5.).
- (5) Hook the rear bracket (see Figure 2.5.) on the center of the back of the helmet and lay the strap with helmet mount bracket over the top of the helmet.
- (6) Hook the helmet mount bracket in the center of the front lip of the helmet and hold it in place (see Figure 2.6.).
- (7) With the buckle lever open, take up the slack in the strap using the catch. Close the buckle lever.

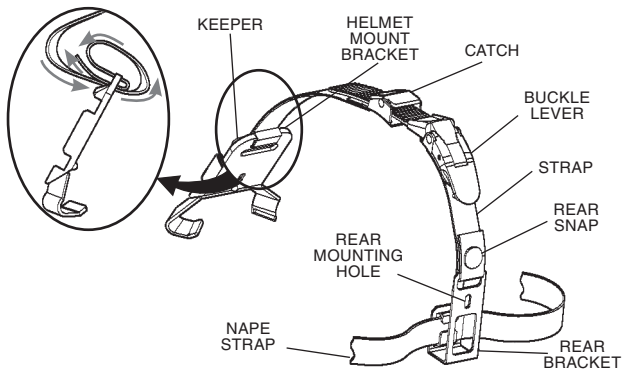

FIGURE 2.4. INSTALLATION OF HELMET MOUNT

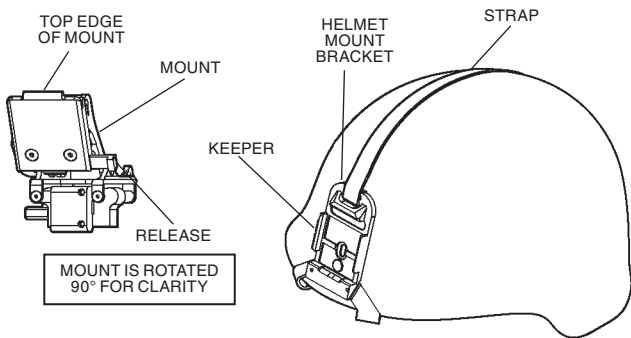

FIGURE 2.5. HELMET MOUNT

- (8) Disengage the nape strap latch on the left side of nape strap.
- (9) Don the helmet. Do not fasten the helmet chinstrap.

(10) Engage the nape strap at the nape strap latch. Tension the nape strap for a stable fit, then install and tension the helmet chin-strap. The brow of the helmet should be parallel to the ground and the helmet stable on the head.

(11) Insert the top edge of the mount under the keeper on the helmet mount bracket and rotate downward until the latch engages (see Figure 2.6.). To release the mount from the helmet bracket, press the release and pull forward and down.

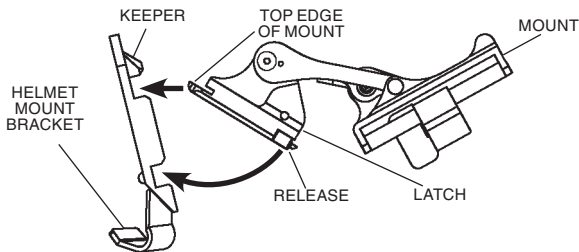

FIGURE 2.6. REASSEMBLY OF HELMET MOUNT

2.1.7. INSTALLATION OF HEADMOUNT WITH PROTECTIVE MASK

Perform the following procedures for donning headmount with protective mask.

(1) Place protective mask on your head per the instructions provided with the protective mask.

WARNING

When installing the headmount over the protective mask, be careful not to break the protective mask seal around your face.

(2) Install the headmount per the instructions in paragraph 2.1.4.

NOTE

It may be necessary to remove the browpad (Figure 2.2.) when wearing the headmount over a protective mask.

2.1.8. INSTALLATION OF WEAPON MOUNT

Perform the following procedure to install the weapon mount.

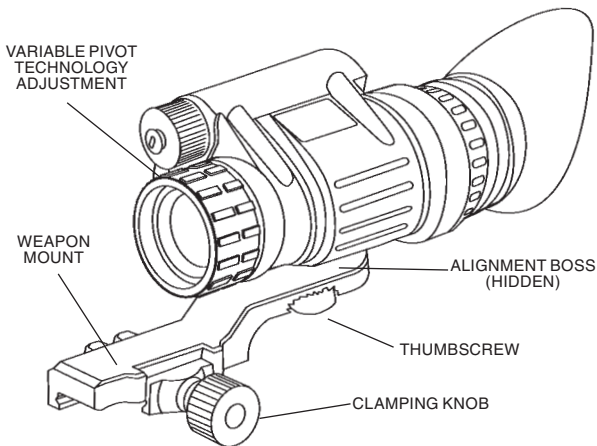

FIGURE 2.7. WEAPON MOUNT USAGE

- (1) Orient the monocular and weapon mount as shown in Figure 2.7. Be sure to align the alignment boss on the weapon mount with the alignment groove in the monocular.
- (2) Screw in the thumbscrew to secure the monocular to the weapon mount.
- (3) Loosen the clamping knob on the weapon mount. Position the weapon mount with the monocular onto the weapon's mounting rail. Tighten by turning the clamping knob.

NOTE

There is a ratchet in the weapon mount that prevents over-tightening of the clamp. Turn until the knob clicks.

(4) Check the position of the monocular by holding the weapon in your normal firing position. Adjust the fore/aft position of the monocular as necessary by loosening the clamping knob and repositioning the weapon mount on the weapon's mounting rail.

(5) To align the image you are viewing. Turn unit on (page 3-4, section 3.2.1) and while viewing the screen rotate the "Variable Pivot Technology adjustment (VPT)" to get image aligned. Please note that the VPT adjustment does not fully Rotate 360 degrees. Icons in OLED display may also be rotated proper alignment. Please refer to section 3.2.2.3 Third Menu Set (page 3-6).

CHAPTER 3

OPERATION

3.1. GENERAL INFORMATION

3.1.1. GENERAL

This section contains instructions for operation of Odin. The function of controls and indicators is explained.

CAUTION

The Odin scope is a precision electron-optical instrument and must be handled carefully at all times.

3.1.2. CONTROLS AND INDICATION

The Odin scope is designed to adjust for different users and corrects for most differences. The controls for the scope are shown or described in Figure 3.1. and Tables 3-1.

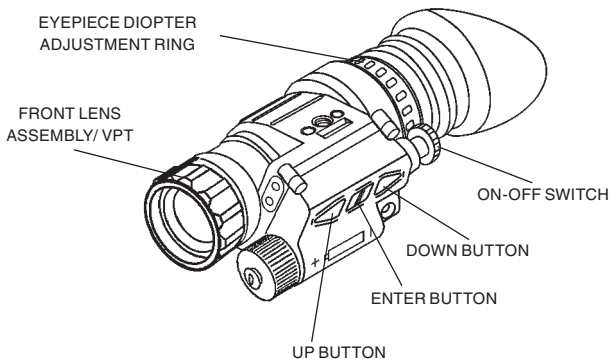

FIGURE 3.1. CONTROLS

Table 3-1. Controls and Indication

ITEMS	CONTROLS AND INDICATORS	FUNCTIONS
1	ON-OFF Switch	Locate the rotary switch next to the eyepiece of the Odin. Simple rotate clockwise to turn on the monocular and allow 4 s for the system start-up. To turn off rotate the switch counterclockwise.
2	UP and DOWN Buttons	Navigating the menu.
3	ENTER Button	Choosing of menu set.
4	Objective Lens Focus	Focus adjustment. Variable pivot technology module
5	Diopter Adjustment	Focuses eyepiece lens without the need for glasses. Adjusts for sharper image of intensifier screen.

3.2. OPERATING PROCEDURE

This section contains operating procedures for using the Odin as hand-held, head mounted, helmet mounted or weapon mounted monocular. Prior to operating the monocular, make certain that all the steps in 2.3.3. Assembly and Preparation for Use, have been read and performed.

3.2.1. TURNING ON

Open the objective lens cover. The objective lens cover protects the monocular from inadvertent exposure to extremely high levels of radiant flux. Never leave the monocular with the objective lens cover off. To turn the unit on rotate clockwise the ON/OFF switch. After a warm-up time of approximately 4 seconds, video of the thermal scene appears.

3.2.2. MENU SETS

The first set of menus appears when you turn on the device. For menu change press ENTER button to cycle through the available menu sets. Each menu contains two icons that indicate various scope functions. To access a particular icon please use UP or DOWN buttons.

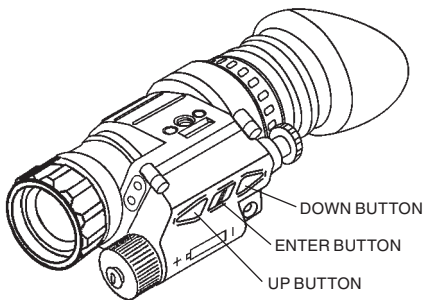

FIGURE 3.2. OPERATIONAL BUTTONS OF ODIN

3.2.2.1. FIRST MENU SET

The two icons on the screen are **Zoom** (on top) accessed by UP button and **White Hot/Black Hot** (on the bottom) accessed by DOWN button.

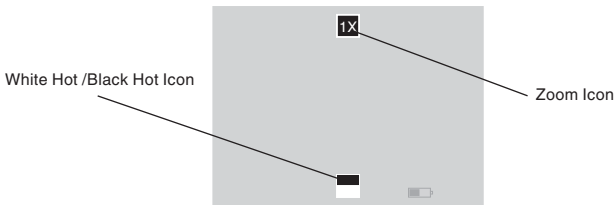

FIGURE 3.3. SCREEN OF FIRST MENU SET

Zoom – UP button will allow the user to cycle through all the zoom options. The icon will change based on the Electronic Zoom level that you have selected. (Note: The Electronic Zoom [E-Zoom] is not the same as overall system magnification. To calculate system magnification you must multiply E-Zoom by Optical Magnification. Example: Odin 32 has an optical magnification on 2X. When used in 1X E-Zoom mode your system overall magnification is 2X [$2 \times 1=2$]. However, when E-Zooming to 2X your system magnification will be 4X [$2 \times 2=4$] and when E-Zooming to 4X your system magnification will be 8X [$2 \times 4=8$].)

White Hot/Black Hot – DOWN button will allow the user to cycle between White Hot Polarity and Black Hot Polarity. When in White Hot mode, the hotter the object the whiter it will appear on the display. In Black Hot the opposite will be true – the hotter the object the darker it will appear. We recommend you try both modes in various environments/situations to determine the optimal mode.

3.2.2.2. SECOND MENU SET

The two icons on the screen are **Color Mode** (on top) accessed by UP button and **Screen Brightness** (on the bottom) accessed by DOWN button.

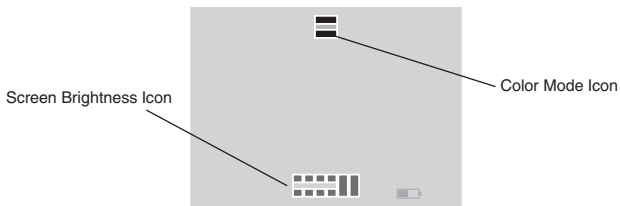

FIGURE 3.4. SCREEN OF SECOND MENU SET

Color Mode – UP button will let the user cycle through various color modes. We recommend that you experiment in various environments/situations to determine which mode works best for you.

Screen Brightness – DOWN button will let the user cycle through display brightness levels. The icon will change to indicate the level of brightness that was chosen.

3.2.2.3. THIRD MENU SET

The two icons on the screen are **Rotate** (on top) accessed by UP button and **Calibrate/NUC** (on the bottom) accessed by DOWN button.

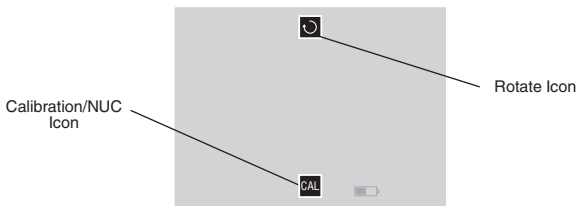

FIGURE 3.5. SCREEN OF THIRD MENU SET

Rotate – UP button will let the user cycle through the screen rotation. This feature offers valuable options to the user in enabling the scope to be used for various purposes. Example: When worn on a headgear/helmet for the left eye (vs more standard right eye approach) the Rotate feature will enable the user to rotate the icons 180 degrees to achieve the proper icon positioning.

NOTE

We highly recommend that you use this feature in combination with the VPT (Variable Pivot Technology) Figure 3.14. to achieve optimal results [3.2.4 and 3.2.5].

Calibrate/NUC – DOWN button will let you Calibrate/NUC the system. Calibrating or NUCing a thermal system is needed when a user detects degradation of the image (image blurring or a burn in effect). This is a normal part of a thermal sensor functionality and is caused by a charge accumulation on the detector array. Most often this will occur when the device is used in an environment with large temperature variations (example: moving from a warm house to a cold outdoor environment). Calibration is needed less when used outdoors at night where temperature variations are less frequent.

To properly Calibrate/NUC the system, user must cover the objective lens either with a lens cap or any other object of uniform temperature (most often even a user's hand will do). Only when the lens is covered the Calibrate feature may be activated. In the event the Calibrate feature is activated and the lens is not covered - the device may experience even a worse degradation as heat sources viewed by the device during calibration are burn-in to the sensor.

NOTE

The burn-in is temporary and causes no permanent damage to the unit.

There are two ways to access Calibrate/NUC function. First is through the 3rd Menu Set as explained above. Second is the Quick Calibration Option – Press both the UP and DOWN keys simultaneously and unit will Calibrate/NUC.

3.2.2.4. FORTH MENU SET

The two icons on the screen are **Reticle Mode** (on top) accessed by UP button and **Video Out ON/OFF** (on the bottom) accessed by DOWN button.

NOTE

For reticle controls please make sure your Odin model comes with the reticle option.

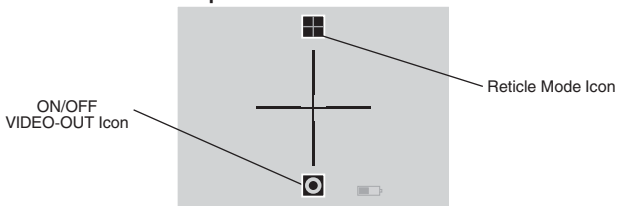

FIGURE 3.6. SCREEN OF FORTH MENU SET

Reticle Mode – UP button will take you to Reticle Adjustment Mode that is made up of three screens – designated as Reticle “A” Screen, Reticle “B” Screen, and Reticle “C” Screen. See “A” through “C” Screens below.

Video Out ON/OFF - DOWN button will activate the video out mode enabling you to transmit video via the video cable (optional). Note: Video Out ON will drain your battery power faster than Video Out OFF.

NOTE

To move between “A” to “C” Screen please use the ENTER Key.

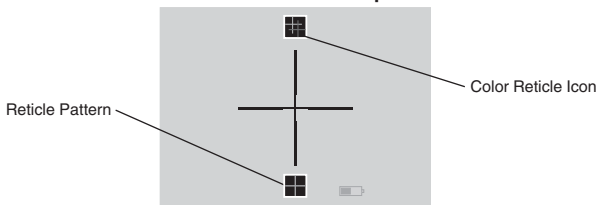

FIGURE 3.7. "A" SCREEN

a. **“A” Screen** - The two icons on the screen are **Color Reticle** (on top) accessed by UP button and **Reticle Pattern** (on the bottom) accessed by DOWN button.

Color Reticle – UP button will cycle through the various color reticles available in your system.

Reticle Pattern – DOWN button will cycle through the various reticle patterns available in your system.

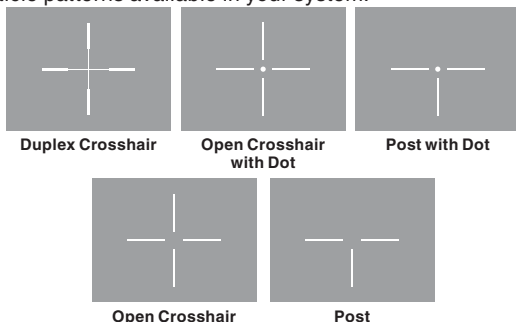

FIGURE 3.8. RETICLE PATTERN

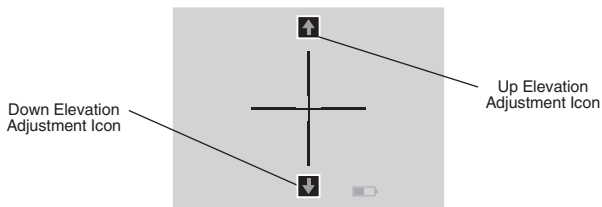

FIGURE 3.9 "B" SCREEN

b. **“B” Screen** - The two icons on the screen are **UP Elevation** (on top) accessed by UP button and **Down Elevation** (on the bottom) accessed by DOWN button.

UP Elevation – UP button will move the reticle Up.

Down Elevation – DOWN button will move the reticle Down.

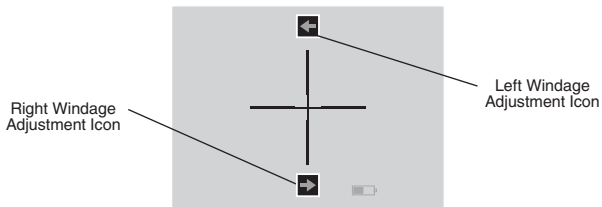

FIGURE 3.10. "C" SCREEN

c. "C" Screen - The two icons on the screen are **Left Windage Adjustment** (on top) accessed by UP button and **Right Windage Adjustment** (on the bottom) accessed by DOWN button.

Left Windage Adjustment – UP button will move the reticle Left.

Right Windage Adjustment – DOWN button will move the reticle Right.

3.2.2.5. FIFTH MENU SET

For the Fifth Menu Set all icons are removed from the screen allowing optimal uncluttered viewing.

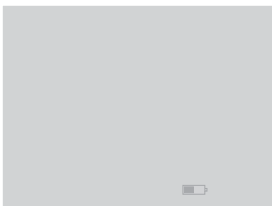

FIGURE 3.11. SCREEN OF FIFTH MENU SET

The UP and DOWN buttons will still function in the same way as on First Menu Set. UP button will activate **Zoom** and DOWN button will activate **White Hot/Black Hot** function.

3.2.3. HAND-HELD OPERATION

NOTE

When using the monocular without a mounting device, make sure to place the neck cord around your neck.

- (1) Ensure that the battery are installed per paragraph 2.1.1.
- (2) Turn the ON-OFF switch to ON.

NOTE

The sharpest image will be observed only when the objective lens and eyepiece lens are properly focused.

- (3) Rotate the diopter adjustment for the clearest view of the image intensifier screen.
- (4) The objective lens is set at fixed focus.
- (5) The objective lens houses the Variable Pivot Technology module. The **VPT** allows the user to rotate the screen to match the angle of the Odin. To do this grab the front lens objective and rotate either clockwise or counterclockwise to the image is at desired location. You can also electronically rotate the icon position in your scope. Select the rotate icon and then adjust through the menu buttons.

3.2.4. HEAD MOUNTED OPERATION

Perform the following procedures for head mounted operation.

- (1) Ensure that battery is installed per paragraph 2.1.1.
- (2) Read the instructions on how to use the headmount in paragraph 2.1.4.

NOTE

To make it easier to align the monocular, eyecup, and eyepiece lens to the eye, depress the eye relief adjustment and slide the headmount socket all the way forward before attaching the monocular.

- (3) Align the headmount/helmet mount adapter's latch to the headmount socket (Figure 3.4.). Press and hold down the latch lever while installing the monocular into the headmount socket. Release the latch when the monocular fully engages the socket.
- (4) Set your eye relief by depressing the eye relief adjustment

(Figure 3.4.) and move the monocular back toward your non-dominant eye until the eyecup comfortably seals around the eye.

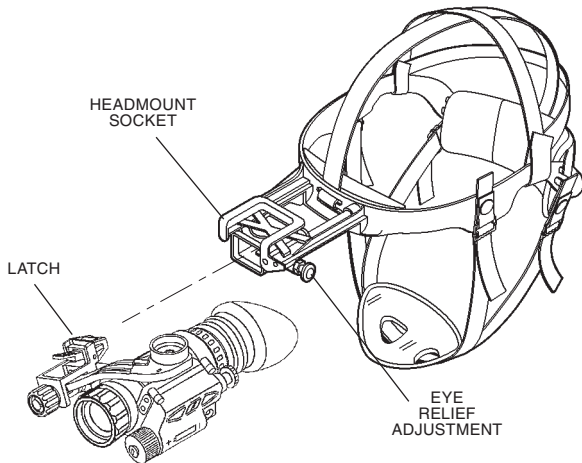

FIGURE 3.12. HEADMOUNT/HELMET MOUNT ADAPTER OPERATION

(5) Turn the monocular ON.

(6) Readjust the vertical adjustment (Figure 2.2.) of the headmount until the monocular is properly aligned with your eye.

NOTE

The sharpest image will be observed only when the objective lens and eyepiece lens are properly focused.

(7) Rotate the diopter adjustment for the clearest view of the image intensifier screen.

NOTE

Any readjustment of eye relief requires readjustment of the diopter.

(8) Adjust the eye relief distance by pressing the eye relief adjustment and sliding monocular fore or aft to obtain a full field of view of the image. Reset the diopter adjustment for best image.

(9) The objective lens is set at infinity focus. The objective lens houses the Variable Pivot Technology module. The VPT allows the user to rotate the screen to match the angle of the Odin. To do this grab the front lens objective and rotate either clockwise or counterclockwise to the image is at desired location. You can also electronically rotate the icon position in your scope. Select the rotate icon and then adjust through the menu buttons.

3.2.5. HELMET MOUNTED OPERATION

CAUTION

Take some precaution when using/handling the helmet mount. Most damage occurs when the helmet mount is left on the helmet when not needed for immediate use. Observe the following cautions to significantly extend the useful life of the helmet mount.

CAUTION

- Do not use excessive force when changing the up/down position of the Odin. Excessive force can break the headmount/helmet mount adapter.
- Do not drop or throw the helmet with the helmet mount attached to it.
- With the monocular in the flipped up position, do not flick the monocular down by shaking the helmet. This places significant stress on the helmet mount.
- All Other Services – Return the helmet and the helmet mount to unit maintenance for direct mounting of the bracket via the helmet screws.

Perform the following procedures for helmet mounted operation.

NOTE

The helmet mount provides two positions for the user to position the Odin. The flipped down position allows the user to position the Odin directly in front of the eyes. The helmet mount also allows the user to rotate the Odin to a flipped up position when the Odin is not needed for immediate use. Both

the flipped down and the flipped up positions have a positive stop which assures the user that the Odin is in the correct position.

NOTE

The headmount/helmet mount adapter allows the Odin to be rotated from the left to the right eye or vice versa. The Odin can be moved to the flipped up position with the headmount/helmet mount adapter positioned to either the left or the right.

- (1) Ensure that the battery is installed per paragraph 2.1.1.
- (2) Install the helmet mount per instructions in paragraph 2.1.6.
- (3) Place the monocular in the socket of the helmet mount.

Set your eye relief by depressing the side buttons (or press down on side lever on metal mount) (see Figure 3.4.) and carefully move the monocular fore or aft until the eyecup comfortably seals around the eye. Readjust the helmet straps as required for vertical adjustment.

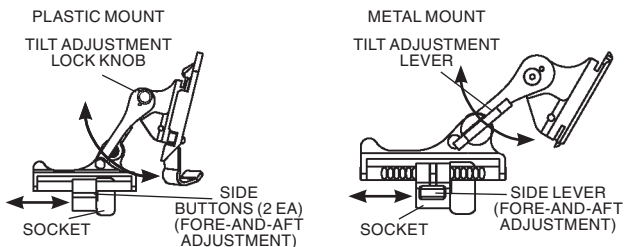

FIGURE 3.13. TILT AND FLIP-UP ASSEMBLY MECHANISMS

- (4) Turn power switch to ON. Adjust the tilt by using the tilt adjustment lock knob (or tilt adjustment lever on metal mount) (Figure 3.4.) until you obtain a comfortable viewing angle.

NOTE

The sharpest image will be observed only when the objective lens and eyepiece lens are properly focused.

- (5) Rotate the diopter adjustment for the clearest view of the image intensifier screen.

NOTE

Any readjustment of eye relief requires readjustment of the diopter.

(6) Adjust the eye relief distance by depressing the side buttons (Figure 3.4.) (or press down on side lever on metal mount) and sliding monocular fore or aft to obtain a full field-of-view of the image. Reset the diopter adjustment for best image.

(7) Adjust the objective lens focus (Figure 1.2.) while observing an object until the sharpest image is obtained.

(8) To flip up, grasp the helmet tilt and flip-up assembly and rotate upward and rearward until the latch is firmly engaged.

WARNING

The monocular will not be turned off automatically when flipped up. The monocular must be turned off by the power switch.

(9) To flip down, grasp the helmet tilt and flip-up assembly and rotate downward and forward until the latch is firmly engaged.

(10) Turn the power switch to the ON position to resume viewing.

(11) Since, the image inside a thermal scope is not a circle but a rectangular box, when mounting the device in various positions you may find that the box is skewed to your vision. To alleviate this situation please use the **VPT** (Variable Pivot Technology) module to make sure the image is properly aligned. The VPT module is adjusted by rotating the front of the objective lens. Do not force the module – it does NOT rotate 360 degrees. You may also need to rotate the Icons to fit your new view – please see 3.2.2.3.

3.2.6. WEAPON MOUNTED OPERATION

NOTE

The Odin can be used as a standalone thermal weapon system.

Perform the following procedures for weapon mounted operation:

(1) Ensure that the battery is installed per paragraph 2.1.1.

(2) Assemble the weapon mount to the monocular per paragraph 2.1.8., steps 1 and 2.

- (3) Mount the monocular with adapter onto the M16/M4 receiver rail per paragraph 2.1.8., steps 3 and 4.
- (4) Rotate the diopter adjustment for the clearest view of the image intensifier screen.
- (5) The objective lens is set at infinity focus. The objective lens houses the Variable Pivot Technology module. The VPT allows the user to rotate the screen to match the angle of the Odin. To do this grab the front lens objective and rotate either clockwise or counterclockwise to the image is at desired location. You can also electronically rotate the icon position in your scope. Select the rotate icon and then adjust through the menu buttons.
- (6) Select the reticle icon in the view screen.
- (7) Adjust the windage and elevation through the selected icons in view screen.

3.2.7. PREPARATION FOR STORAGE

- (1) Shutdown. Perform the following procedures to shut down the monocular.
 - (a) Turn the monocular power switch to the OFF position.
 - (b) Remove the monocular from the headmount, helmet mount or weapon and remove the weapon mount from the monocular.

WARNING

Do not carry batteries in pockets containing metal objects such as coins, keys, etc. Metal objects can cause the batteries to short circuit and become very hot.

- (2) Packaging After Use.
 - (a) Remove battery cap and remove battery.
 - (b) Inspect the battery housing for corrosion or moisture. Clean and dry if necessary.
 - (c) Replace the battery cap.
 - (d) Remove the demist shield or sacrificial window if installed. Install objective lens cap.

NOTE

- **Prior to placing Odin into carrying case, ensure Odin and**

case are free of dirt, dust, and moisture.

- The monocular and helmet mount should not be left on the helmet when the helmet is removed.

(e) Refer to Figure 1.1. for proper placement of demist shield, battery, carrying case strap, lens paper, manual, browpads, head-mount, helmet mount, headmount/helmet mount adapter and weapon mount.

(f) Place the monocular into the shallow pocket of the carrying case.

(g) Place the carrying case into the shipping and storage case, close and latch (Figure 1.3.).

(h) Return to storage area.

3.2.8. VARIABLE PIVOT TECHNOLOGY

To align the image you are viewing.

You can align the image to a desired angle by rotating the “Variable Pivot Technology adjustment (VPT)”.

Turn unit on (page 3-4, section 3.2.1) and while viewing the screen rotate the “Variable Pivot Technology adjustment (VPT)” to get image aligned. Please note that the VPT adjustment does not fully Rotate 360 degrees. Icons in OLED display may also be rotated proper alignment. Please refer to section 3.2.2.3 Third Menu Set (page 3-6).

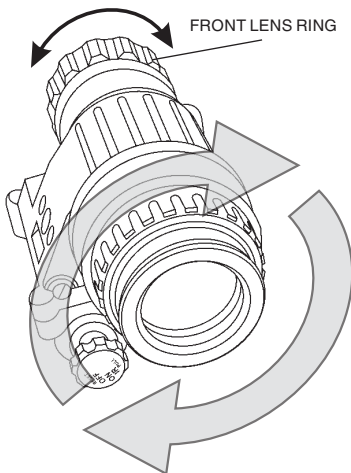

FIGURE 3.14. VPT

CHAPTER 4

MAINTENANCE INSTRUCTIONS

4.1. LUBRICATION INSTRUCTIONS

No lubrication is required.

4.2. TROUBLESHOOTING PROCEDURES

4.2.1. TROUBLESHOOTING

Table 4.1. lists common malfunctions that you may find with your equipment. Perform the tests, inspections and corrective actions in the order they appear in the table.

This table cannot list all the malfunctions that may occur, all the tests and inspections needed to find the fault, or all the corrective actions needed to correct the fault. If the equipment malfunction is not listed or actions listed do not correct the fault, notify your maintainer.

TABLE 4.1. OPERATOR'S TROUBLESHOOTING.

MALFUNCTION	TEST OR INSPECTION	CORRECTIVE ACTION
1. Monocular fails to activate.	Visual.	Turn power switch to OFF position and then ON.
2. Poor image quality.	Check for defective, missing or improperly installed battery.	Replace battery or install correctly.
	Check objective lens or eyepiece lens focus.	Re Calibrate/NUC. Refocus.
3. Light visible around eyecup.	Check for fogging or dirt on objective lens or eyepiece lens.	Clean lens surface per paragraph 3.2.
	Check eye relief distance.	Readjust for proper eye relief distance.
4. Diopter adjustment cannot be made.	Check eyecup for resiliency.	If eyecup is defective, refer to higher level of maintenance.
	Check to see if the diopter adjustment is bent or broken.	If damaged, refer to higher level of maintenance.
5. Battery cap difficult to open.	Visually inspect for the presence of an o-ring.	If o-ring is missing, refer to higher level of maintenance.
	Check for damaged battery cap.	If damaged, refer to higher level of maintenance.
6. Head straps cannot be tightened.	Check for defective buckles, fasteners or straps.	If damaged, refer to higher level of maintenance.

MALFUNCTION	TEST OR INSPECTION	CORRECTIVE ACTION
9. Headmount or helmet mount socket and headmount/ helmet mount adapter latch does not catch.	<p>Check socket or latch for dirt.</p> <p>Check socket or latch for damage.</p>	<p>Clean socket and latch.</p> <p>If damaged, return either headmount or helmet mount socket and headmount/helmet mount adapter to higher level of maintenance.</p>
10. Helmet mount will not tighten to helmet.	Inspect mounting hardware for damage.	If damaged, refer to higher level of maintenance.

4.3. OPERATOR'S MAINTENANCE PROCEDURES

4.3.1. CLEANING THE SCOPE

CAUTION

- The monocular is a precision electro-optical instrument and must be handled carefully.
- Do not scratch the external lens surfaces or touch them with your fingers.
- Wiping demist shield with lens paper while wet or with wet lens paper can damage the coating.

Clean monocular with water if necessary and dry thoroughly. Clean lenses with lens paper (and water if necessary, except for the demist shield).

4.3.2. HEADMOUNT MAINTENANCE

a. Browpad Replacement

Replace the browpad when cracked, torn, or contaminated. Perform the following procedures to remove and replace the browpad.

- (1) Firmly grasp the headmount and remove the old browpad.
- (2) Gently press on the new browpad. Lightly smooth out any wrinkles in the new browpad.

b. Neck Pad Reinstallation

During operation of the Scope, it is possible for the neck pad to become separated from its position on the headband. Perform the following procedure to reinstall the neck pad.

- (1) Lift the upper headband strap retention tab (see Figure 4.1.) allowing the neck pad strap to be inserted underneath.
- (2) Slip the neck pad strap all the way under the upper strap retention tab and then pull the lower part of the neck pad strap under the lower strap retention tab.
- (3) Repeat steps 1 and 2 for the other side of the headband and neckband if necessary.

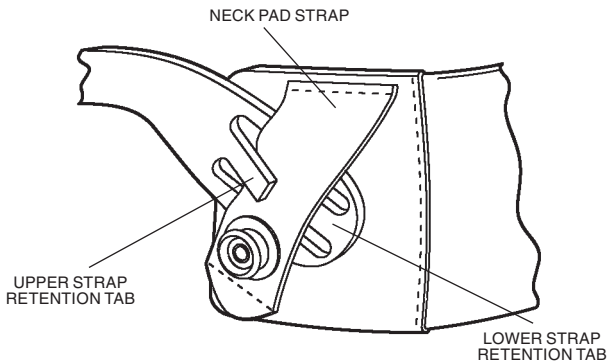

FIGURE 4.1. REINSTALLING THE NECK PAD

c. Lacing the Sliding Bar Buckles

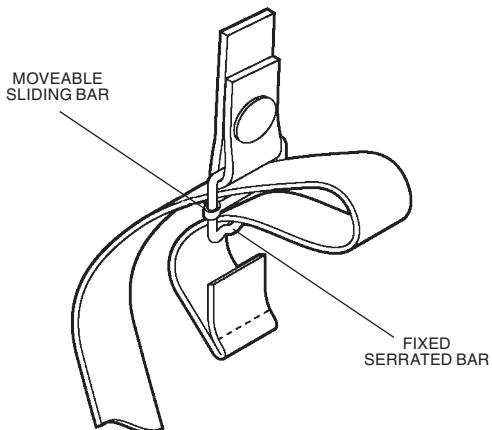

FIGURE 4.2. THREADING THE SLIDING BAR BUCKLES

While donning and adjusting the headmount, it is possible for a strap to slip out of a slide fastener. Perform the following procedure to adjust the strap and sliding bar buckle.

(1) Thread the strap from the inside of the buckle over the moveable sliding bar (see Figure 4.2.). Thread the strap back through the buckle but this time under the moveable sliding bar and over the serrated part of the buckle.

(2) Pull the strap through the buckle and tighten as necessary.

(3) Repeat steps 1 and 2 for other straps and buckles that may have come undone.

4.3.3. NECK CORD MAINTENANCE

The neck cord (Figure 1.1.) may be broken, frayed, or loose at one or both ends.

If loose, re-tie cord. If broken or severely frayed, install new cord as follows:

(1) Insert ends through monocular holes from the rear.

(2) Thread right cord end through hole in objective lens cap.

(3) Tie a knot in each end.



For customer service and technical support, please contact

American Technologies Network Corp.

1341 San Mateo Avenue, South San Francisco, CA 94080

phone: 800-910-2862, 650-989-5100; fax: 650-875-0129

www.atncorp.com