



PVS-7

NIGHT VISION GOGGLES



OPERATION AND MAINTENANCE MANUAL

Important Export Restrictions! Commodities, products, technologies and services of this manual are controlled by the U.S. Department of State Office of Defense Trade Controls, in accordance with International Traffic in Arms (ITAR), Title 22, Code of Federal Regulations Part 120-130 and/or by the Export Administration Regulations (EAR) of U.S. Department of Commerce. At any time when a license or a written approval of the U.S. Government is applicable to it, it is illegal and strictly forbidden to export, intend to export, transfer in any other manner whatsoever, sell any hardware or technical data, provide any associated service to any non-U.S. resident, beyond or within the United States territory, until the valid license or written approval has been issued by the Departments of the U.S. Government having jurisdiction. Additionally U.S. law prohibits the sale, transfer, or export of items to certain restricted parties, destinations, and embargoed countries, as identified on lists maintained by the U.S. Department of State, the U.S. Department of Commerce, and the U.S. Department of Treasury. It is the responsibility of the Customer to be aware of these lists. The sale, transfer, transportation, or shipment outside of the U.S. of any product prohibited or restricted for export without complying with U.S. export control laws and regulations, including proper export licensing, documentation or authorization, is unlawful and may result in civil and/or criminal penalties and/or constitute a federal crime. Diversion contrary to U.S. law is strictly prohibited.



SAFETY SUMMARY

Before operating this product, carefully read and study this Operation and Maintenance Manual.

The PVS-7 is a precision electron-optical instrument, and requires careful handling. To avoid damage to the equipment or physical harm to the user when operating the PVS-7, follow all WARNINGS, CAUTIONS and NOTES.

Below you will find definitions of the following alerts that appear throughout this Manual:

WARNING — Identifies a clear danger to the person operating the equipment.

CAUTION – Identifies risk of damage to the equipment.

NOTE – Serves to highlight essential procedures, conditions, and statements, or convey important instructional data to the user.

WARNING:

This product contains natural rubber latex which may cause allergic reactions! The FDA has reported an increase in the number of deaths that are associated with an apparent sensitivity to natural latex proteins. If you are allergic to latex, it is a good idea to learn which products contain it and strictly avoid exposure to those products.

WARNINGS:

- When used in total darkness, the light from the unit's infrared (IR) illuminator is invisible to the unaided eye. However, the light can be detected by other Night Vision Devices (NVD).
- To reduce the risk of detection by another NVD, avoid prolonged activation of the IR illuminator.
- The IR light is more easily detected by an NVD when used in smoke, fog and rain. Avoid prolonged activation of the unit's IR illuminator in these conditions.
- The intensifier's phosphor screen contains toxic materials. Please note the following:
 - If the intensifier tube breaks, be extremely careful to avoid inhaling the phosphor screen material. **DO NOT** allow the material to come in contact with your mouth, eyes, or any open wounds on the skin.
 - If the phosphor screen material comes in contact with your skin, wash it off immediately with soap and water.
 - If you inhale or swallow any phosphor screen material, drink a lot of water, induce vomiting, and seek medical attention as soon as possible.

The information provided in this manual is for familiarization purposes only; the contents may undergo further changes with no commitment by Armasight® to notify Customers of any updates.

Armasight® assumes no responsibility for any misprints or other errors that this manual may contain.

©2012 by Armasight. All rights reserved.

CAUTION:

- The PVS-7 is a precision optical instrument. To prevent damage to the unit, it should always be handled carefully.
- Do not scratch the external lens surfaces or touch them with your fingers.
- To protect the image intensifier, keep the lens cap securely fitted over the objective lens when the device is not in use, or when it is being used in daylight conditions.
- The IR illuminator produces light that is invisible to a naked eye, so that it can be used in conditions of extreme darkness. However, the IR light can be detected by other NVDs.
- Use of rubber eyecups for extended periods of time may cause skin inflammation. If any symptoms develop, consult a doctor immediately.

NOTES:

- Do not test the device in daylight conditions for more than ten (10) minutes, even with the daylight filter/ lens cap on.
- To protect the device from damage, do not direct it at bright light sources (fire, automobile headlights, lanterns, etc.).
- The purpose of the built-in IR illuminator is to provide additional illumination when necessary while viewing scenes at close distances (up to 3 meters).
- The unit is equipped with an Automatic Shut-off System. When the goggles are removed from the head mount or helmet mount while turned on, they will turn off automatically. To turn the unit on after automatic shut off, you will need to rotate the operation knob to the OFF position first and then return it to the ON position.
- To avoid physical danger to the user and damage to the equipment, carefully read and understand the following equipment limitations:
 - The equipment requires some ambient light (moonlight, starlight, etc.) to operate.
 - Performance of the device in nighttime conditions depends on the level of ambient light in the environment. Please remember the following:
 - The level of ambient light is reduced by the presence of clouds, shade, or objects that block natural light (trees, buildings, etc.).
 - The equipment is less effective when operated in shadows and other darkened areas.
 - The equipment is less effective when operated in rain, fog, sleet, snow, dust or smoke.
 - The equipment will not “see” through dense smoke.

LIST OF CONTENTS

TITLE	PAGE
Safety Summary	2
List of Contents	4
How to Use This Manual	6
1. INTRODUCTION	7
1.1 General Information	7
1.1.1 Type of Manual	7
1.1.2 Model Number and Equipment Name	7
1.1.3 Purpose of Equipment	7
1.1.4 Reporting Equipment Improvement Recommendations	7
1.2 Warranty Information and Registration	8
1.2.1 Warranty Information	8
1.2.2 Limitation of Liability	8
1.2.3 Product Warranty Registration	8
1.2.4 Obtaining Warranty Service	9
1.3 Cross References	9
1.4 List of Abbreviations	10
2. DESCRIPTION AND DATA	11
2.1 System Description	11
2.2 Specifications	13
2.3 Operation principles	14
2.3.1 Mechanical Functions	14
2.3.2 Optical and Electrical Functions	15
3. OPERATING INSTRUCTIONS	16
3.1 Operating Procedures	16
3.1.1 General	16
3.1.2 Controls and Indicators	16
3.2 Preventive Maintenance Checks and Services (PMCS)	18
3.2.1 Purpose of PMCS	18
3.2.2 Frequency of Performing PMCS	18
3.2.3 Performance of PMCS	18
3.3 Assembly and Preparation	20
3.3.1 Preparation of Use	20
3.3.2 Installation of the Quick Disconnect Helmet Mount Assembly	26
3.3.3 Operating Procedures	27
3.3.4 Preparation for Storage	32
4. MAINTENANCE INSTRUCTIONS	33
4.1 Troubleshooting Procedures	33
4.1.1 Troubleshooting	33
4.2 Identification of Operational Defects	34
4.2.1 Operational defects	34
4.2.2 Cosmetic Blemishes	35

4.3 Maintenance	36
4.3.1 General	36
4.3.2 Head Mount Maintenance	37
4.4 Service/Packing and Unpacking	37
4.4.1 Return Instructions	37
APPENDIX	38
A. PVS-7 List of Spare Parts	38
B. Product Warranty Registration Card	41
Alphabetical Index	43

LIST OF FIGURES

FIGURE	TITLE	PAGE
2-1	PVS-7 Components	12
2-2	Mechanical Controls for PVS-7	14
3-1	PVS-7 Controls	16
3-2	Battery and Eye cap Installation	21
3-3	Installation of Demist Shields, Sacrificial Window	22
3-4	Installation of Compass	23
3-5	Installation of the IR Spot/Flood Lens	23
3-6	PVS-7 Head Mount Adjustments	24
3-7	Helmet Mount Features	25
3-8	Neck Strap Installation	26
3-9	Quick Disconnect Helmet Mount Features	26
3-10	Flip-up Helmet Mount	29
3-11	View Through Installed Compass	30
3-12	PVS-7 with Magnifier Lens Assembly Installed	31
3-13	PVS-7 Shipping/storage case	32
4-1	Shading	35
4-2	Edge Glow	35
4-3	Emission Points and Bright Spots	36
4-4	Fixed-Pattern Noise	36
4-5	Chicken Wire	36
4-6	Re-installing the Neck Pad	37
4-7	Lacing the Sliding Bar Buckles	38

LIST OF TABLES

TABLE	TITLE	PAGE
2-1	PVS-7 System Description	12
2-2	PVS-7 Optional Equipment	12
2-3	Operator Adjustment Limits	13
2-4	Electrical Data	13
2-5	Mechanical Data	13
2-6	Optical Data	13
2-7	Environmental Data	14
2-8	Consumable Items	15
3-1	Controls and Indicators	17
3-2	Preventive Maintenance Checks and Services	18
3-3	Estimated Battery Life	21
4-1	Operator's Troubleshooting	33
A-1	PVS-7 List of Spare Parts	39

HOW TO USE THIS MANUAL

USAGE

You must familiarize yourself with the entire manual before operating the equipment. Before performing any kind of maintenance on your device, read the section on maintenance in its entirety. Follow all **WARNINGS**, **CAUTIONS**, and **NOTES**.

MANUAL OVERVIEW

This manual contains sections on Operating and Maintaining the PVS-7 Night Vision Goggles.

The list of Spare Parts can be found in Appendix A.

The Product Warranty Registration Card can be found in Appendix B.

INTRODUCTION

1.1 GENERAL INFORMATION

1.1.1 TYPE OF MANUAL

Operation and Maintenance.

1.1.2 MODEL NUMBER AND EQUIPMENT NAME

PVS-7 Night Vision Goggles

1.1.3 PURPOSE OF EQUIPMENT

To provide the operator with the ability to observe scenes at night, under moonlight and starlight conditions.

The PVS-7 can be used as a handheld, head-mounted or helmet-mounted device. When mounted to the head or a helmet, the user will be able to easily operate the device while walking, performing short-range surveillance, reading maps, performing vehicle maintenance, or administering first aid.

The PVS-7 allows for horizontal and vertical adjustments when mounted to the user's head or helmet, and is equipped with an infrared light-emitting source (IR illuminator).

1.1.4 REPORTING EQUIPMENT IMPROVEMENT RECOMMENDATIONS

Armasight encourages user recommendations for improvements to the device.

Mail your comments to:

Armasight Inc.

815 Dubuque Avenue

South San Francisco, CA 94080

USA.

Or, you can send an email to info@armasight.com.

1.2 WARRANTY INFORMATION AND REGISTRATION

1.2.1 WARRANTY INFORMATION

This product is guaranteed to be free from manufacturing defects in material and workmanship under normal use for a period of two (2) years from the date of purchase. In the event that a defect covered by the below warranty occurs during the applicable period stated above, Armasight, at its discretion, will either repair or replace the product; such action on the part of Armasight shall be the full extent of Armasight's liability, and the Customer's sole and exclusive repair. This warranty does not cover a product if it has (a) been used in ways other than its normal and customary manner; (b) subjected to misuse; (c) subjected to alterations, modifications or repairs by the Customer of by any party other than Armasight without prior written consent of Armasight; (d) special order or "close-out" merchandise or merchandise sold "as-is" by either Armasight or the Armasight dealer; or (e) merchandise that has been discontinued by the manufacturer and either parts or replacement units are not available due to reasons beyond the control of Armasight. Armasight shall not be responsible for any defects or damage that in Armasight's view are a result from the mishandling, abuse, misuse, improper storage or improper operation of the device, including use in conjunction with equipment that is electrically or mechanically incompatible with, or of inferior quality to, the product, as well as failure to maintain the environmental conditions specified by the manufacturer. CUSTOMER IS HEREBY NOTIFIED THAT OPERATION OF THE EQUIPMENT DURING DAYLIGHT HOURS OR UNDER ANY EXCESSIVE LIGHT CONDITIONS MAY PERMANENTLY DAMAGE THE INTERNAL COMPONENTS OF THE UNIT AND SAID DAMAGE WILL NOT BE COVERED UNDER THIS WARRANTY. This warranty is extended only to the original purchaser. Any breach of this warranty shall be enforced unless the Customer notifies Armasight at the address noted below within the applicable warranty period.

The Customer understands and agrees that except for the foregoing warranty, no other warranties written or oral, statutory, expressed or implied, including any implied warranty of merchantability or fitness for a particular purpose, shall apply to the product. All such implied warranties are hereby and expressly disclaimed.

1.2.2 LIMITATION OF LIABILITY

Armasight will not be liable for any claims, actions, suits, proceedings, costs, expenses, damages or liabilities arising out of the use of this product. Operation and use of the product are the sole responsibility of the Customer. Armasight's sole undertaking is limited to providing the products and services outlined herein in accordance with the terms and conditions of this Agreement. The provision of products sold and services performed by Armasight to the Customer shall not be interpreted, construed, or regarded, either expressly or implied, as being for the benefit of or creating any obligation toward any third party of legal entity outside Armasight and the Customer; Armasight's obligations under this Agreement extend solely to the Customer. Armasight's liability hereunder for damages, regardless of the form or action, shall not exceed the fees or other charges paid to Armasight by the Customer or Customer's dealer. Armasight shall not, in any event, be liable for special, indirect, incidental, or consequential damages, including, but not limited to, lost income, lost revenue, or lost profit, whether such damages were foreseeable or not at the time of purchase, and whether or not such damages arise out of a breach of warranty, a breach of agreement, negligence, strict liability or any other theory of liability.

1.2.3 PRODUCT WARRANTY REGISTRATION

In order to validate the warranty on your product, Armasight must receive a completed Product Warranty Registration Card for each unit, or the Customer can complete a warranty registration form on our website at www.armsight.com. Please complete the included form (Appendix C) and immediately mail it to our Service Center:

Armasight Inc.

815 Dubuque Avenue

South San Francisco, CA 94080

USA

1.2.4 OBTAINING WARRANTY SERVICE

To obtain warranty service on your unit, the End-user (Customer) must notify the Armasight service department via email. Send any requests to service@armasight.com to receive a Return Merchandise Authorization number (RMA). When returning any device, please take in the product to your retailer, or send the product, postage paid and with a copy of your sales receipt, to Armasight Corporation's service center at the address listed above. All merchandise must be fully insured with the correct postage; Armasight will not be responsible for improper postage or merchandise that becomes lost or damaged during shipment. When sending product back, please clearly write the RMA# on the outside of the shipping box. Please include a letter that indicates your RMA#, the Customer's Name, a Return Address, reason for the return, Contact information (valid telephone numbers and/or an e-mail address), and proof of purchase that will help us to establish the valid start date of the warranty. Product merchandise returns that do not have an RMA# listed may be refused, or a significant delay in processing may occur. Estimated Warranty service time is 10-20 business days. The End-user/ Customer is responsible for postage to Armasight for warranty service. Armasight will cover return postage/ shipping after warranty repair to the End-user/ Customer only if the product is covered by the aforementioned warranty. Armasight will return the product after warranty service by domestic UPS Ground service and/ or domestic mail. Should any other requested, required or international shipping methods be necessary, the postage/ shipping fee will be the responsibility of the End-user/ Customer.

1.3 CROSS REFERENCES

COMMON NAME	OFFICIAL NAME
Allen Wrench	Socket Head Screw Key
Battery Compartment	Battery Box Cover
Shipping Case	Textile Bag
Cotton Swab	Disposable Applicator
Neoprene Jack Plug	Plug Assembly
O-Ring	Gasket
Safety Screw	Electrical Dial-Knob Lock
Pattern Generator	Optical Instrument Reticule
Lens Covers	Exit Port Covers
Paddle Switch	Remote Cable Switch
Batteries	AA
Technical Manual	Operator and Field Maintenance Manual
Tape Fastener Loop	Fastener, Loop Tape
Tape Fastener Hook	Fastener, Hook Tape

1.4 LIST OF ABBREVIATIONS

C	Celsius (Centigrade)
CCW	counterclockwise
Cont'd	Continued
CW	clockwise
Dia	diameter
F	Fahrenheit
FOV	Field of View
g	gram
Gen	Generation
H	Height
hr	hour
IR	infrared
IT	Intensifier Tube
L	Length
LED	Light Emitting Diode
lx	lux
m	meter
mA	milliampere
min	minute
mm	millimeter
mW	milliwatt
nm	nanometer
No	Number
NV	Night Vision
NVD	Night Vision Device
Para	Paragraph
PMCS	Preventive Maintenance Checks and Services
QRM	Quick Release Mount
QTY	Quantity
RMA#	Return Merchandise Authorization number
s	second
seq	sequence
SR	Service Representative
VDC	Volts Direct Current
V	Volt
W	Width

DESCRIPTION AND DATA

2.1 SYSTEM DESCRIPTION

The PVS-7 is a hand-held, head-mounted or helmet-mounted night vision system that enables mobility, driving, weapon firing, short-range surveillance, map reading, vehicle maintenance and administering first aid during operation in both moonlight and starlight. Each unit allows for vertical adjustment (using the head straps), fore-and-aft adjustment, objective lens focus, eyepiece focus and eye relief distance adjustment. The goggles are also equipped with an infrared (IR) light-emitting diode (or illuminator) and a low battery LED indicator. The goggles automatically shut off when disconnected from the head mount or helmet mount, or when flipped up on the helmet mount. A bright light cutoff feature shuts off power to the goggles when they are exposed to excessive levels of light for more than 70 (± 30) seconds.

The PVS-7 includes the items shown in Figure 2-1. See Table 2-1, Table 2-2 and Figure 2-1 for Standard and Optional Equipment.

A. Goggles Assembly. The goggles assembly consists of four primary sub-assemblies; a simple objective lens, a wired housing assembly, an image intensifier tube (IIT) assembly (not shown), and a rear cover assembly. The wired housing assembly contains a built-in battery compartment, attached battery cap and the RESET/ OFF-ON-IR/ PULL switch.

B. Head mount Assembly. The adjustable, cushioned head mount assembly secures the goggles to the operator's head, providing hands-free operation and allowing the use of weapons, protective masks and other devices. The thin brow pad (intended for use with larger heads) comes attached to the head mount. Thicker, or medium, brow pads (intended for use with smaller heads) are stored in the carrying case.

C. Carrying Case. The canvas carrying case is provided for transportation and protection of the PVS-7, head mount assembly, batteries and accessories. Two slide keepers are provided for belt attachment. A carrying case strap, which can be attached to the two D-rings on the back of the carrying case, is also included. The case has a zipper closure.

D. Demist Shields. The two demist shields are used to prevent the eyepiece lenses from becoming fogged.

E. Sacrificial Window. A replaceable sacrificial window is supplied to protect the objective lens during operation in adverse conditions.

F. Neck Cord. This additional authorized item can be attached to the compass or 3X magnifier lens and worn by the operator to prevent them from dropping or losing these items.

I. Optional Equipment. Optional equipment includes compass, helmet mount assembly, 3x and 5x Mil-Spec Magnifier Lenses, Long Range Infrared illuminator, Mil-Standard Hard Shipping/Storage Case and an IR spot/ flood lens.

The PVS-7 may sometimes be supplied in hard shipping and storage case. Batteries may also be stored in this case.

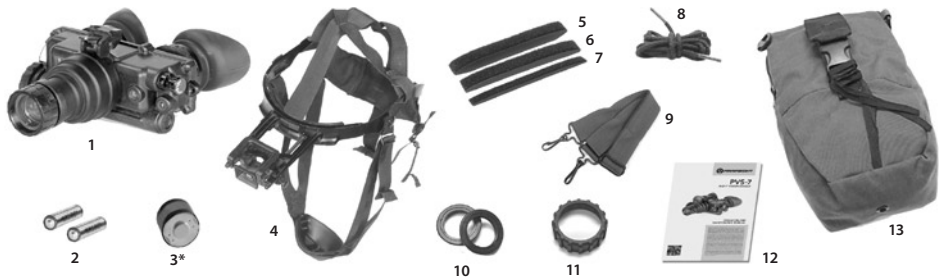

FIGURE 2-1. PVS-7 COMPONENTS

TABLE 2-1. PVS-7 SYSTEM DESCRIPTION

ITEM	DESCRIPTION	ITEM	DESCRIPTION
1	PVS-7 Assembly	8	Neck Cord
2	AA Alkaline Batteries	9	Shoulder Strap Assembly
3*	Image intensifier Tube	10	Demist Shield Assembly
4	Large Brow Pad Head mount Assembly	11	Sacrificial Window
5	Large Brow Pad	12	Operator's Manual
6	Medium Brow Pad	13	Carrying Case
7	Thin Brow Pad	14	Lens Paper (Not Shown)

* Equipment with variants.

TABLE 2-2. PVS-7 OPTIONAL EQUIPMENT

ITEM	DESCRIPTION	PART NO.
1	MICH Helmet Mount Assembly USA #107	ANHM000005
2	PASGT Helmet Mount Assembly USA #108	ANHM000006
3	3x Mil-Spec Magnifier Lens #99	ANAF3X0003
4	5x Mil-Spec Magnifier Lens #100	ANAF5X0001
5	Magnetic Compass #110	ANKI000009
6	SKB Mil-Standard Hard Shipping/Storage Case (F100)	ANH000001
7	IR Spot/Flood Lens	ANLE000001

2.2 SPECIFICATIONS

The following tables provide information pertaining to the operational, electrical, mechanical, optical and environmental characteristics for the goggles.

TABLE 2-3. OPERATOR ADJUSTMENT LIMITS

ITEM	LIMITS
Interpupillary Distance	55 to 71mm
Diopter Focus	+2 to -6 diopters
Objective Focus	25cm to infinity

TABLE 2-4. ELECTRICAL DATA

ITEM	DATA
Power Source	Battery (3 VDC max.)
Battery Requirements	2 AA Alkaline or 1 Lithium (BA-5567/U)

TABLE 2-5. MECHANICAL DATA

ITEM	DATA
Shipping and Storage Case	Size: Approx. 17"x12"x7" Weight: 6.7 lbs.
Soft Carrying Case	Size: Approx. 14"x8"
Goggles *	Size: 6.4"x6"x3" Weight 1.5 lbs

* The weight of the PVS-7 does not include accessories.

TABLE 2-6. OPTICAL DATA

ITEM	DATA
Magnification	1.0X
Field of View	40°
Eyepiece Focus	+2 to -6 diopters
Focus Range	25cm (9.8") to infinity

TABLE 2-7. ENVIRONMENTAL DATA

ITEM	DATA
Operating Temperature	-40°C to +50°C
Storage Temperature	-50°C to +70°C
Illumination Required	Overcast starlight to moonlight
Waterproof	1 meter for 30 min.

2.3 OPERATION PRINCIPLES

2.3.1 MECHANICAL FUNCTIONS

Mechanical adjustments of the PVS-7 allow for physical differences between individual operators using the system. The goggles' functions include the power switch, interpupillary adjustment, release latch, eye relief adjustment, diopter adjustment, IR spot/ flood focus (optional), compass illumination (optional), and objective lens focus. The mechanical controls are identified in Figure 2-2.

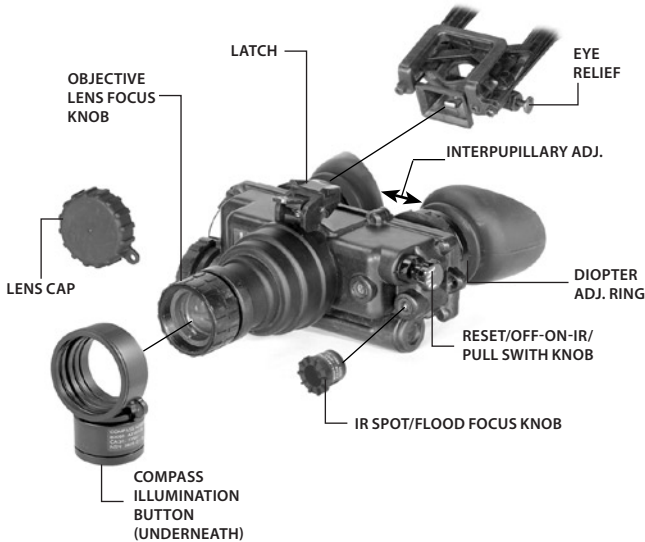

FIGURE 2-2. MECHANICAL CONTROLS FOR PVS-7

2.1.2 OPTICAL AND ELECTRICAL FUNCTIONS

The optical functions include an objective lens, image intensifier, a collimator lens, and two eyepieces. The objective lens collects light reflected from the moon, stars or other ambient light in the night sky, and inverts and focuses an image of the scene onto the image intensifier. The electrical functions include the following:

A. Power Source. The electronic circuit is powered by replaceable batteries - either a 3.0 Volt lithium battery (BA-5567/U) or two AA 1.5 Volt alkaline batteries (BA-3055/U).

B. Electrical Principles. Power from the batteries is supplied to the components through the RESET/OFF-ON-IR/ PULL switch as follows:

RESET/ OFF Position. With the switch in the OFF position, the circuit will not supply energy to the image intensifier or the IR illuminator. You can also turn the switch to this position to reset your device after automatic shutoff or bright light cutoff.

ON Position. Energy is drawn from the battery compartment to power the goggles. When the voltage drops to 2.4 VDC, a low battery indicator will begin to blink on the right side region of the eyepiece, indicating approximately 30 minutes of remaining operating time.

IR/ PULL Position. Energy is drawn from the battery compartment to power the goggles and IR light source, and a steady red indicator light will appear in the left side region of the eyepiece. The IR can be momentarily turned on by turning the switch ON without pulling the knob.

C. Automatic Shutoff. When the goggles are removed from the head mount or helmet mount while in on and in use, they will automatically shut off. This prevents detection by other NVDs by eliminating the green glow of the image intensifier. To turn the goggles back on, flip the switch to RESET/ OFF and then back to ON again.

D. High Light Cutoff. The goggles will automatically shut off after 70 (± 30) seconds of operation in daylight or bright room light. Individual bright lights (headlights, flashlights or other concentrated light sources) will not activate the high light cutoff function, unless the light is focused directly onto the high light detector located on the front of the goggles. To turn the goggles back on, flip the switch to RESET/ OFF and then back to ON again.

2.1.3 CONSUMABLE ITEMS

Items listed in Table 2-8 are recommended for operator maintenance.

TABLE 2-8. CONSUMABLE ITEMS

ITEM	LIMITS
Lens Paper	-
Color Swabs	-
Alcohol	-

OPERATING INSTRUCTIONS

3.1 OPERATING PROCEDURES

3.1.1 GENERAL

This section contains instructions for operating the PVS-7 under normal conditions. Explanations of control functions and indicators are provided.

CAUTION:

The PVS-7 is a precision electro-optical instrument and must be handled carefully at all times.

3.1.2 CONTROLS AND INDICATORS

The PVS-7 is adjustable to accommodate different users and corrects for most differences in eyesight. The controls and indicators for the PVS-7 are shown or described in Figure 3-1 and Table 3-1.

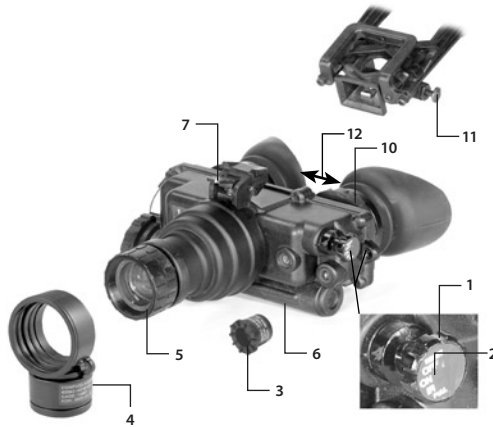

FIGURE 3-1. PVS-7 CONTROLS

TABLE 3-1.CONTROLS AND INDICATORS

ITEM	CONTROLS AND INDICATORS	FUNCTIONS
1	RESET/OFF-ON-IR/PULL	<p>Controls goggles and IR light power. ON or OFF.</p> <p>RESET/ OFF: Same as system OFF. Also resets goggles after automatic shut-off or high light cutoff.</p> <p>ON: Goggles activated.</p> <p>IR/PULL: Pull switch out and turn clockwise to activate goggles and IR. Illuminates LED indicator in left eyepiece.</p>
<p>NOTES: Some PVS-7's contain an additional momentary IR function. For momentary IR, continue to turn the switch knob clockwise, past ON and without pulling. The switch will return to the ON position when released.</p>		
2	RESET/OFF-ON-IR/PULL Label	Defines the switch positions.
3	IR Spot/Flood Lens	Focuses the IR light for a narrow beam (spot) or wide angel (flood) beam illumination.
4	Compass Illuminator Button	Pressing this button activates the compass illuminator LED, which makes compass readings visible in the goggles' viewing area. Additional pressure will make the image brighter. The image will disappear when the button is released.
5	Objective Focus	Focuses objective lens. Adjusts for sharpest image of viewed object.
6	Battery Polarity Indicator	This feature is molded into the PVS-7 and shows the proper orientation of the batteries.
7	Latch	The latch is used to separate the goggles' assembly from the head mount/ helmet mount's assembly.
8	LED On Indicator (Not Shown)	When illuminated (left eyepiece), this light indicates that the IR illumination is on.
9	Low Battery Indicator (Not Shown)	When illuminated (right eyepiece), this light indicates a low battery condition with less than 30 minutes of battery life remaining.
10	Diopter Adjustment Ring	Focuses eyepiece lens for each eye without the need for glasses. Adjusts for sharper image on intensifier screen.
11	Interpupillary Adjustment	Adjusts the distance between each eyepiece by sliding them together or apart, allowing for each eye to observe the entire field at the same time.
12	Eye Relief	Adjusts the distance between your eyes and the goggles.

3.2 PREVENTIVE MAINTENANCE CHECKS AND SERVICES (PMCS)

3.2.1 PURPOSE OF PMCS

PMCS should be performed daily when the PVS-7 is in use in order to ensure that the sight is mission-ready at all times. Procedures are a systematic inspection of the goggles that will enable you to discover defects that could cause the PVS-7 to fail on a mission.

3.2.2 FREQUENCY OF PERFORMING PMCS

You should perform PMCS as follows:

- A. Daily when the PVS-7 is in use.
- B. Weekly when in standby condition.
- C. Semi-annually when stored in depot or administrative storage.

3.2.3 PERFORMANCE OF PMCS

Preventive maintenance checks and services should be performed in the sequence and inspection procedures indicated in Table 3-2.

TABLE 3-2. PREVENTIVE MAINTENANCE CHECKS AND SERVICES

SEQUENCE NO.	ITEM TO BE INSPECTED/ PROCEDURE
1	GOGGLES - Check for completeness, including accessories. Check for dirt and moisture on external surfaces and parts. Clean and dry with a lint-free cloth.
2	SHIPPING CASE - Check for dirt, moisture and mildew. Clean with a mild detergent and water. Dry with a lint-free cloth.
3	CARRYING CASE - Check for dirt, moisture and mildew. Clean with a mild detergent and water. Dry with a lint-free cloth.
4	BATTERIES - Remove batteries. Check for corrosion on terminals and dirt or moisture in the battery cap. Clean battery cap with a dry cloth. Replace the batteries if corroded.
5	LENSES - Check for dirt and moisture. Clean with lens paper or a brush and/ or alcohol and cotton swabs.
6	EYECUPS - Check for dirt, dust, cracked or torn cups. Inspect for bent, broken or improperly fitting eyecups.
7	INTERPUPILLARY ADJUSTMENT - Slide each eyepiece back and forth to check for binding or looseness.
8	OBJECTIVE LENS FOCUS KNOB - Rotate objective lens focus knob to ensure free movement (range is approximately 1/3 turn).
9	NECK CORD & LENS CAP- Check for cracked, torn or missing lens cap. Inspect cord for cuts, damage or frayed ends. Re-tie ends if necessary.
10	LATCH - Inspect for damage.
11	RESET/ OFF-ON-IR/ PULL SWITCH - Remove any batteries and turn the switch from RESET/OFF to ON or IR/ PULL. Each position should have a definite stopping point. Inspect for broken or missing knob.

TABLE 3-2. CONTINUED

SEQUENCE NO.	ITEM TO BE INSPECTED/ PROCEDURE
HEAD MOUNT	
12	STRAPS AND PADS - Check for cuts tears, fraying, holes, cracks or defective fasteners.
13	SOCKET - Check for dirt, dust or corrosion. Insert the goggles' latch into the socket to verify the secure attachment of the goggles to the head mount. If necessary, clean the socket with water.
14	FORE-AND-AFT ADJUSTMENT - Press the socket-release button and check for free motion. Inspect for damage.
OPTIONAL HELMET MOUNT	
15	STRAPS - Inspect for cuts, tears, fraying, holes, cracks or defective fasteners
16	SOCKET - Check for dirt, dust or corrosion. Insert goggles latch into socket to verify secure attachment of goggles helmet mount. If necessary, clean socket with water.
17	FORE-AND-AFT ADJUSTMENT - Press the socket-release button and check for free motion. Inspect for damage.
18	FLIP-UP/ AUTO OFF - With the goggles on, flip them up and verify the operation of the auto-off function.
19	TILT ADJUSTMENT - Verify that the knob locks tilt while in place, and that the full range of the tilt is reached when the knob is loosened.
20	SOFT CARRYING CASE - Remove all items and shake out loose dirt or foreign material. Inspect for tears, cuts, excess wear or damage to mounting clips.
21	SHOULDER STRAP ASSEMBLY - Inspect for cuts, tears or excess wear of clips.
NOTES:	
Damaged optional items (compass, IR spot/ flood, sacrificial window, demist shields) do not make the assembled unit to be "not fully mission capable." However, the damaged item should be replaced as soon as practical to restore full capability of the system.	
ACCESSORY ITEMS	
22	DEMIST SHIELDS - Inspect for dirt, dust, scratches or damage. If necessary, clean when the shields are dry and with dry lens paper only.
23	IR SPOT/ FLOOD LENS - Rotate IR focus lens to ensure free movement.
24	COMPASS ASSEMBLY - Inspect for dirt, dust, scratches or damage. If necessary, clean with water and dry with lens paper. Install the compass assembly and turn the goggles on. When the illumination button is depressed, the compass should be visible.
25	3X/5X AFOCAL MAGNIFIER LENS - Check lens for scratches or damage. Check mating to objective lens by screwing it in or pressing it on with the adapter installed.

3.3 ASSEMBLY AND PREPARATION

3.3.1 PREPARATION FOR USE

This chapter contains information necessary to prepare the goggles for operation. This includes unpacking, examination for damage, battery installation, sacrificial window installation, and head mount installation and adjustments.

A. Unpacking. The following steps must be accomplished prior to each mission.

CAUTION:

Before releasing the latches on the carrying case, relieve air pressure from inside the shipping and storage case by pressing the relief valve button located near the handle of the carrying case.

1. Release the two latches securing the top of shipping and storage case, and open the top.
2. Check the contents of the shipping and storage case for completeness (see Figure 1-1).
3. Remove the carrying case from the shipping and storage case. Open the carrying case (Figure 1-1), remove the PVS-7 and check contents for completeness.
4. Inspect the goggles for obvious evidence of damage to optical surfaces, body, eyecups, RESET/ OFF-ON-IR /PULL switch, battery cap, etc. Ensure that all optical surfaces are clean and ready for use. If necessary, clean with lens paper.

B. Installation of Batteries.

CAUTION:

To protect the image intensifier, keep the lens cap securely fitted over the objective lens when the goggles are not in use or when performing daylight checks.

NOTE:

Operation of the PVS-7 in daylight conditions will activate the high light cut off after 70 (\pm 30) seconds, causing the goggles to shut down.

WARNING:

The lithium battery contains sulfur dioxide gas under pressure.

Do not heat, puncture, disassemble, short circuit, attempt to recharge or otherwise tamper with the batteries.

Turn off the equipment if the battery compartment becomes excessively hot. If possible, wait until the batteries have cooled before removing them.

These types of batteries have safety vents to prevent explosion. When they are venting gas, they release a very potent smell, and you may hear the sound of gas escaping. When the safety vents have worked correctly, the batteries will be fairly safe from bursting, but because of excessive heat still must be handled with extreme care.

If you inhale sulfur dioxide, seek medical attention immediately.

The PVS-7 will operate with either of the two battery types identified in Table 2-3. Batteries are not supplied with the PVS-7 and must be purchased by the user.

TABLE 3-3. ESTIMATED BATTERY LIFE

BATTERY TYPE	NEGLECTIBLE IR USAGE	IR USAGE 10% OF THE TIME
Lithium (BA-5567/U)	47-85 Hours	36-65 Hours
AA Alkaline (BA-3058/U)	89-160 Hours	68-123 Hours

NOTE:

The battery data in Table 2-4 represents operation at room temperature. When operating in cooler conditions, battery life will decrease.

CAUTION:

Always verify that the Reset/ off-on IR/ pull switch is in the **off** position before installing batteries.

Install either two (2) AA batteries or one (1) BA-5567/ U lithium battery as follows. Do not attempt to mix battery types in the compartment.

1. Remove the battery cap by turning it counterclockwise.
2. Verify that the o-ring is present. If not, replace it.
3. Observe the polarity markings on the outside of the battery compartment and insert either two AA, 1.5 Volt batteries or one 3.0 Volt BA-5567/U lithium battery into the battery compartment, plus (+) end first. (See Figure 3-2)
4. Secure the battery cap back on by placing it over the compartment and turning it clockwise. Verify that it is firmly tightened to ensure a watertight seal.

C. Installation of the Eyecups. Perform the following procedure to install the eyecups onto the PVS-7. Refer to Figure 3-2.

1. Carefully press each eyecup over the diopter cell retainer.
2. Rotate each eyecup into the proper viewing position. Adjust for the best fit. The eyecups must seal around your eyes and prevent the light from the green glow from escaping.

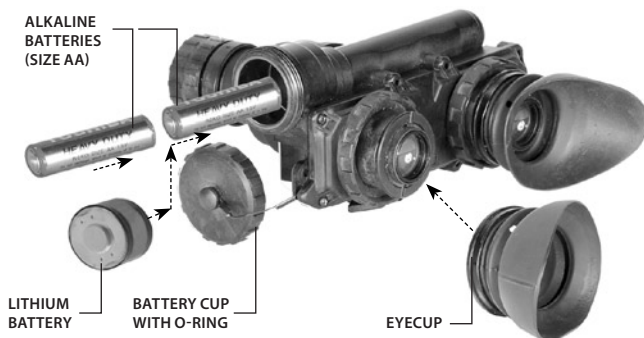
**FIGURE 3-2. BATTERY AND EYE CAP INSTALLATION**

D. Installation of the Demist Shields. Perform the following procedure to install the demist shields on the diopter lenses. Refer to Figure 3-3.

CAUTION:

If the demisting shields need to be cleaned, make sure the shields are dry and only use dry lens paper. If the demist shields are wiped while wet or with wet lens paper, you will damage the coating.

NOTE:

If inclement operating conditions are known to be a possibility prior to your mission (e.g. significant temperature change and high humidity), install the demist shields before operation in order to minimize diopter lens fog.

1. Carefully remove the eyecups.
2. Carefully press a demist shield onto each eyepiece. Be careful not to smudge the eyepieces or demist shields.
3. Replace the eyecups (see paragraph 3.3).

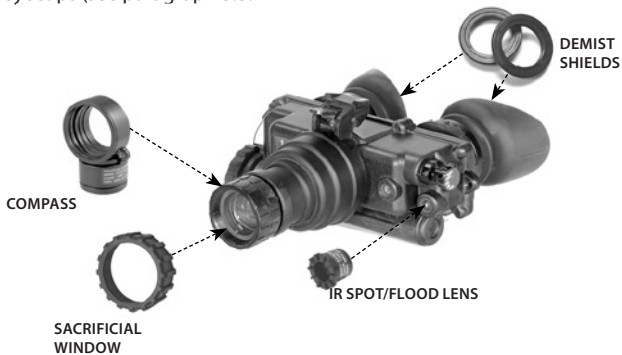

FIGURE 3-3. INSTALLATION OF DEMIST SHIELDS, SACRIFICIAL WINDOW

E. Installation of the Sacrificial Window. Perform the following procedure to install the sacrificial window. Refer to Figure 3-3.

CAUTION:

If adverse operating conditions (dust or sand), are known to exist, attach the sacrificial window to protect the objective lens from scratches or other damage.

1. If the compass assembly or lens cap is in place, remove it.
2. Carefully push the sacrificial window over the objective lens until it stops. Turn the sacrificial window clockwise until it snaps into place.

F. Installation of the Compass Assembly.

NOTES:

- a. Prepare the PVS-7 for operation (paragraph 3.3.1).
- b. Ensure the neck cord is secured to the compass and clothing before installing.

1. If the sacrificial window or lens cap is in place, remove it.
2. Turn the PVS-7 on.

3. While looking through the goggles, rotate the objective lens focus completely counterclockwise.
4. Press the compass assembly onto the objective lens at an angle using your left hand. Slowly turn the compass assembly counterclockwise until it is in the vertical position (with the compass illumination button pointing down). See Figure 3-4.
5. Ensure that the compass fits tightly to the PVS-7.

NOTE:

The o-ring must be in place in the compass assembly in order for the compass to fit properly.

6. Refer to paragraph 3.3.3, D for operation of the compass.



FIGURE 3-4. INSTALLATION OF COMPASS

G. Installation of the IR Spot/Flood Lens.

1. Press the IR spot/ flood lens over the IR source until it is tight against the goggles. Refer to Figure 3-5.



FIGURE 3-5. INSTALLATION OF THE IR SPOT/FLOOD LENS

H. Installation and Adjustment of the Head Mount Assembly. Perform the following procedures for putting the head mount on.

NOTE:

Do not put the head mount on while the PVS-7 is attached to it.

1. Prior to putting on the head mount, loosen the four chin straps so the ends of each strap are approximately two inches from the sliding bar buckles (See Figure 3-6)
2. Snap the front and rear snaps into place.

NOTE:

If the head mount is too loose, remove the attached thin brow pad and replace with either the medium or large brow pad (both are stored in the carrying case). Refer to Chapter 3, paragraph 3-4 for removal and replacement of the brow pads.

3. With both hands, grasp the neck pad assembly. Pull the harness over your head and the neck pad down to the back of your neck.
4. While holding the chin cup in position on your chin, adjust both rear chin cup assembly straps until you feel light pressure against your chin. (DO NOT TIGHTEN).
5. Maintain the position of the chin cup and remove any slack from the front and rear chin straps. (DO NOT TIGHTEN).
6. Ensure that the cross-strap assembly is not twisted and remove any slack by adjusting the vertical adjustment strap on the neck pad.
7. Adjust the chin strap and vertical adjustment until the chin cup and headband assembly fit comfortably but firmly.

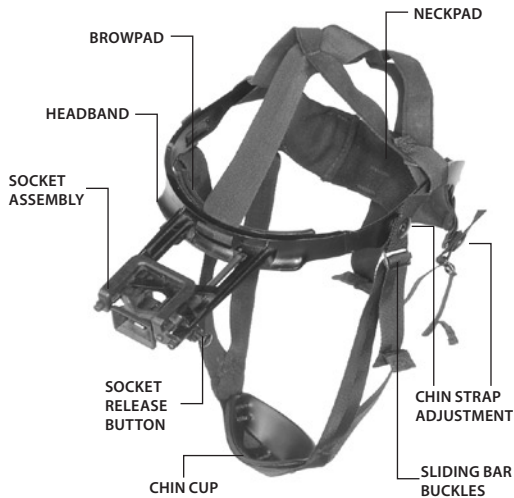

FIGURE 3-6. PVS-7 HEAD MOUNT ADJUSTMENTS

NOTE:

After installing the PVS-7, minor strap adjustments may be necessary to achieve comfort.

8. Refer to paragraph 3.3.3, A for operating procedures of the head mount assembly.

I. Installation of the Head Mount Assembly with a Protective Mask. Perform the following procedures for putting on the head mount with a protective mask.

1. Place protective mask on your head per the instructions provided with the mask.

WARNING:

When installing the head mount over the protective mask, be careful not to break the protective mask seal around your face.

2. Install the head mount assembly per instructions in paragraph 3.3.1, H.

NOTE:

It may be necessary to remove the brow pad when wearing the head mount over a protective mask.

J. Installation of the Head Mount Assembly with the PASGT Helmet. Install the head mount assembly per the instructions in paragraph 3.3.1, H.

K. Installation of the Head Mount Assembly with the M1 Helmet. Install the head mount assembly per the instructions in paragraph 3.3.1, I.

L. Installation of the Helmet Mount Assembly (Optional) to the PASGT Helmet.

1. Remove mount assembly from the carrying case. Refer to Figure 3-7 for the helmet mount features.

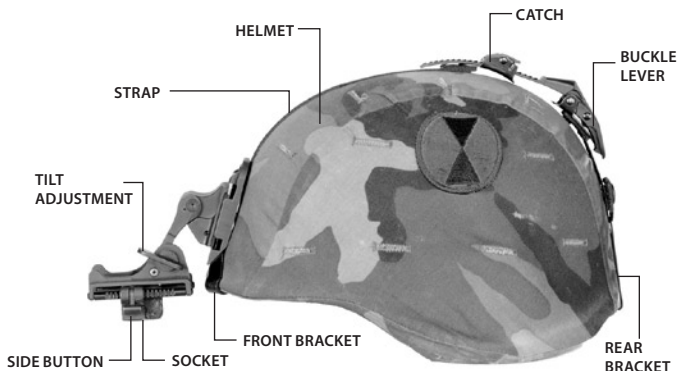

FIGURE 3-7. HELMET MOUNT FEATURES

2. With the catch flipped forward, place the strap over the top of the helmet, center and hook the rear bracket onto the rear of the helmet. Center the front bracket, hook in on the front of the helmet and hold it in place. (See Figure 3-7.)
3. With the buckle-lever open, take up the slack in the strap using the catch. Close the buckle lever.
4. Place the helmet upside down with the helmet mount facing you.

NOTE:

Steps 5 and 6 describe the installation of the neck strap to the chin strap. To accomplish these steps, it may be necessary to unthread the chin strap from the helmet.

5. Thread the chin strap through the right end of neck strap and snap the neck strap fastener tab closed. (Refer to Figure 3-8.)
6. Thread the chin strap through the left end of the neck strap and snap the neck strap fastener tab closed. (Refer to Figure 3-8.)
7. Unfasten the neck strap latch on the left side of the neck strap.
8. Put the helmet on.
9. Fasten the neck strap with the neck strap latch. Tighten the chin strap and neck strap until they fit securely. The brow of the helmet should be parallel to the ground.

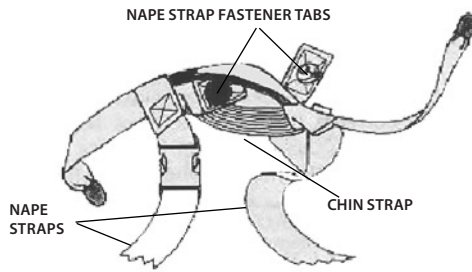

Loop the nape strap fastener tabs around the corners of the chin strap and snap closed. After closure, the snaps will be on the outside, away from your chin.

FIGURE 3-8. NAPE STRAP INSTALLATION

3.3.2 INSTALLATION OF THE QUICK DISCONNECT HELMET MOUNT ASSEMBLY

1. Remove the helmet mount assembly from the carrying case. Make sure the helmet mount is complete. Refer to Figure 3-9 for helmet mount components and features.

CAUTION:

To prevent possible equipment damage, remove both the goggles and the mount assembly from the helmet when not required for immediate use. The clip/ strap assembly can remain in place on the helmet.

2. If the mount assembly and clip/ strap assembly are connected, remove the mount assembly. To do this, push the release lever at the top center of the mount and slide the two assemblies apart.
3. Adjust the clip/ strap assembly to fit the helmet size being used.
4. With the catch in the fully extended, place the strap over the top of the helmet, center and hook the rear bracket onto the rear of the helmet. Center the front bracket hook on the front of the helmet and hold it in place.
5. With the buckle lever open, tighten the slack in the clip/ strap assembly using the catch. Close the buckle lever.
6. If the PASGT helmet has its cloth cover and camouflage strap installed, it will be necessary to slide the camouflage strap up (at an approximately 30°-45° angle) at the front of the helmet (see Figure 3-9).

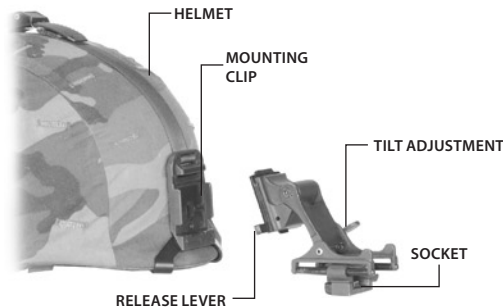

FIGURE 3-9. QUICK DISCONNECT HELMET MOUNT FEATURES

7. Unfasten the neck strap latch on the left side of the neck strap.
8. Put the helmet on. Do not fasten the helmet chin strap.
9. Fasten the neck strap using the neck strap latch. Tighten the neck strap until it fits securely, then install and tighten the helmet chin strap. The brow of the helmet should be parallel to the ground and the helmet should be stable on the head.
10. To install the mount assembly into the clip/ strap assembly, slide its top flange into the top groove of the mounting clip and press the mount assembly bottom until it locks into place with a click (see Figure 3-9).

3.3.3 OPERATING PROCEDURES

This section contains operating procedures for using the PVS-7 as a hand-held, head-mounted, or helmet-mounted device. Prior to operating the goggles, ensure that all the steps in paragraph 2-6 have been read and performed.

A. Head-mounted Operation. Perform the following procedures for head-mounted operation.

CAUTION:

Only operate the PVS-7 in dark environments. If you must operate the device in daylight, use the lens cap to cover the objective lens.

NOTE:

Proper objective focus cannot be achieved while the objective lens cap is covering the objective lens. Objective focus must be done in the dark with the objective lens cover removed.

1. Ensure that the batteries are installed per paragraph 3.3.1, B.
2. Wear the head mount per the instructions in paragraph 3.3.1, H.

NOTE:

Paragraphs 3.3.1, J, K and L provide additional information that is required to install the head mount with a protective mask, PASGT or M1 helmet.

To make it easier to align the goggles, eyecups and diopter eyepieces with your eyes, depress the socket-release button (See Figure 3-6) and slide the head mount socket completely forward before attaching the goggles.

3. Align the PVS-7's latch (Figure 3-1) to the head mount socket (See Figure 3-7). Press and hold down on the latch lever while installing the goggles into the head mount socket. Release the latch when the goggles are fully installed in the socket.
4. For maximum eye comfort, depress the socket-release button and move the PVS-7 backwards until the eyecups comfortably seal around your eyes.
5. Turn the RESET/ OFF-ON-IR/ PULL switch ON.
6. Adjust the interpupillary distance (Figure 3-1) by sliding the eyepieces together or apart so each eye can observe the entire field of view at the same time. The eyepieces adjust independently.
7. Readjust the vertical strap assembly (see Figure 3-6) for vertical adjustment of the head mount; the PVS-7 should be properly aligned with your eyes.

NOTE:

The sharpest image can only be viewed when the objective lens and both eyepieces are properly focused. The objective lens focus adjustment is used to focus on objects at varying distances. The diopter adjustment rings are used to focus your eyesight (without glasses) on the image intensifier screen. These adjustments operate independently and must be made separately.

8. Fold the right eyecup over the eyepiece with your right thumb or forefinger to obstruct the view through the right eyepiece. Rotate the left diopter adjustment ring until you observe the clearest possible view through the image intensifier screen.
9. Fold the left eyecup over the eyepiece with your left thumb or forefinger to obstruct the view through the left eyepiece. Rotate the right diopter adjustment ring until you observe the clearest possible view through the image intensifier screen.
10. Adjust the eye relief distance by pressing the socket release button (See Figure 3-1) and sliding the PVS-7 fore or aft until you can observe the full field of view. Readjust the diopter rings for the sharpest, clearest image.

NOTE:

Any changes to maximize eye relief will require readjustment of the diopter rings.

11. While viewing an object with the device, adjust the objective lens focus (Figure 2-1) until the image becomes sharp and clear.

B. Helmet-mounted Operation. Perform the following procedures for helmet-mounted operation.

1. Verify that the batteries are installed per paragraph 3.3.1, B.
2. Put the helmet mount on per the instructions in paragraph 3.3.1, M.
3. Place the PVS-7 in the socket of the helmet mount (See Figure 3-7). To set your eye relief focus, depress the side buttons and carefully move the goggles fore or aft until the eyecups are comfortably sealed around the eyes. Readjust the helmet straps as required for vertical adjustment.
4. Turn the power switch ON. Adjust the tilt by using the tilt adjustment lock knob (Figure 3-1) until you reach a comfortable viewing angle.
5. Adjust the interpupillary distance (Figure 3-1) by sliding the eyepieces together or apart so that each eye can observe the entire field of view at the same time. The eyepieces adjust independently. If necessary, readjust the eye relief.

NOTE:

The sharpest image will only be observed if the objective lens and both eyepieces are properly focused. The objective focus adjustment is used to focus on objects at varying distances. The diopter adjustment rings are used to focus your eyesight (with or without glasses) through the image intensifier screen. These adjustments operate independently and must be made separately.

6. Fold the right eyecup over the eyepiece with your right thumb or forefinger to obstruct the view through the right eyepiece. Rotate the left diopter adjustment ring until you observe the clearest view possible through the image intensifier screen.
7. Fold the left eyecup over the eyepiece with your left thumb or forefinger to obstruct the view through the left eyepiece. Rotate the right diopter adjustment ring until you observe the clearest view possible through the image intensifier screen.
8. To adjust the eye relief distance, press the socket release button (see Figures 3-1) and slide the PVS-7 fore or aft until you are able to observe the full field of view. Readjust the diopter rings for the clearest image.

NOTE:

Any changes to maximize eye relief will require readjustment of the diopter rings.

9. While observing an image through the device, adjust the objective lens focus (Figure 3-1) until the image becomes sharp and clear.
10. To flip the device up, place your hand under the goggles, grasp the goggles and rotate them up and backwards until the latch is firmly engaged.

NOTE:

The PVS-7 will turn off automatically when flipped up. The PVS-7 will not turn on automatically when flipped back down; you will need to turn it on manually.

11. To flip the device down, grasp the goggles and rotate them down and forwards until the latch is firmly engaged.
12. To resume operation, turn the switch to the RESET/ OFF position, then to the ON position.



FIGURE 3-10. FLIP-UP HELMET MOUNT

C. Hand-Held Operation**CAUTION:**

Operate the PVS-7 only in dark environments. If you need to operate the device in daylight, always use the lens cap to cover the objective lens.

NOTE:

When using the PVS-7 without a mounting device, always use the neck cord.

1. Verify that the batteries are installed per paragraph 3.3.1, B.
2. Turn the RESET/ OFF-ON-IR/ PULL switch ON.
3. Adjust the interpupillary distance (Figure 3-1) by sliding the eyepieces together or apart so that each eye can observe the entire field of view at the same time. The eyepieces adjust independently.
4. Hold the PVS-7 with your left hand and fold the left eyecup over the eyepiece with your left thumb or forefinger to obstruct the view through the left eyepiece. Rotate the right diopter adjustment ring until you are able to observe the clearest possible view through the image intensifier screen.
5. Hold the PVS-7 with your right hand and fold the right eyecup over the eyepiece with your right thumb or forefinger to obstruct the view through the right eyepiece. Rotate the left diopter adjustment ring until you are able to observe the clearest possible view through the image intensifier screen.
6. While looking through the device, readjust the objective lens assembly until the image becomes sharp and clear.

D. Operation with Compass Assembly

NOTE:

The objective lens focus can be fine-tuned after installation, but in order to obtain an accurate reading, the compass must be vertical; the compass image must be level.

1. Install per paragraph 3.3.1, F.
2. For a clearer view of objects at a distance, adjust the objective focus by gripping the compass and turning it clockwise.
3. To view the compass through the PVS-7, grip the compass with your index finger on top and your thumb on the illumination button on the bottom (Figure 3-4). Press the button slightly with your thumb until the proper brightness is reached. The image should appear as shown in Figure 3-11.

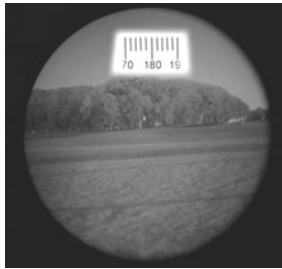

FIGURE 3-11. VIEW THROUGH INSTALLED COMPASS

NOTE:

Increase the brightness slowly. If brightness is increased too quickly, excessive brightness may burn a temporary image into the image intensifier. The goggles must be focused at or near infinite for proper compass operation.

4. The compass readings should change when you move your head from side to side. Rotate or tap the compass slightly to ensure that it is operating correctly. Hold the PVS-7 in a level position to verify live rotation of the compass scale.

WARNING:

The compass illuminator can be seen by other night vision devices.

NOTE:

The compass reading is magnetic North, not true North. The compass reading is within 2° of correct absolute magnetic bearing. Compass readings with a mounted PVS-7 (head mount or helmet mount) can be up to ±15° of correct absolute magnetic bearing. This occurs most in the East (90°) to West (270°) reading, and less in the North (0°) to South (360°) reading. If the compass is inadvertently magnetized, this could cause an additional 15° error.

5. The tick mark closest to the center of the lighted display is the compass bearing. The tick marks are in degrees, with longer marks every five (5) degrees and bearing labels every ten (10) degrees.

E. Use of the 3X or 5X Magnifier Lens Assembly. When the sacrificial window is removed, the 3X or 5X magnifier lens assembly can be threaded directly into the 1X objective lens.

NOTE:

The neck cord can be used to tether the magnifier to the operator, in order to prevent losing the lens if it is dropped. To use the neck cord, tie the end without the clip tightly around the magnifier and attach the clip to a buttonhole, belt loop or other convenient point.



FIGURE 3-12. PVS-7 WITH MAGNIFIER LENS ASSEMBLY INSTALLED

F. Infrared (IR) Operations

WARNING:

Light from the IR illuminator is invisible to the naked eye in extreme darkness. However, it can be detected by other night vision devices.

1. Pull the RESET/OFF-ON-IR/PULL switch knob (Figure 2-1) out and rotate clockwise to the IR position. With the PVS-7 held to the eyes, observe that a red light appears in the left eyepiece. This indicates that the IR illuminator is operating. When spring loaded momentary IR position is used, the illuminator should only flash on.
2. To Operate with the IR Spot/Flood Lens: Pull the RESET/OFF-ON-IR/PULL switch knob out and rotate clockwise to the IR position. With the PVS-7 held to the eyes, turn the IR spot/flood until you have achieved the optimum illumination of the desired distance. Turn the RESET/OFF-ON-IR/PULL switch counterclockwise to the ON position. Observe that the red indicator disappears.

3.3.4 PREPARATION FOR STORAGE

A. Shut down.

Perform the following procedures to shut down the PVS-7.

1. Turn the RESET/ OFF-ON-IR/ PULL switch OFF.
2. Remove the PVS-7 from the head mount or helmet mount (if applicable) by depressing the latch lever (Figure 3-1) and removing the PVS-7 from the head mount socket.

B. Packaging After Use.

1. Unscrew the battery cap and remove the battery(ies).
2. Inspect the battery compartment for corrosion or moisture. Clean and dry if necessary.
3. Replace the battery cap.
4. Remove the demist shields, sacrificial window or compass assembly if installed. Replace the lens cap.

NOTE:

Prior to placing the PVS-7 assembly into the carrying case, ensure that the goggles and case are free of dirt, dust and moisture.

5. Place the demist shields, batteries, carrying case strap, lens paper, sacrificial window, manual, brow pads, head mount, helmet mount and compass into the carrying case.
6. Place the PVS-7 (objective lens down) into the shallow pocket of the carrying case.
7. Place the carrying case into the shipping/ storage case; close and latch it.
8. Return it to a safe storage area.

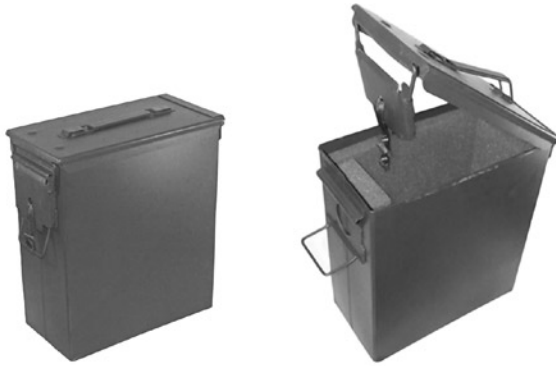

FIGURE 3-13. PVS-7 SHIPPING/STORAGE CASE

PREVENTIVE MAINTENANCE AND TROUBLESHOOTING

4.1 TROUBLESHOOTING

4.1.1 OPERATOR TROUBLESHOOTING

Table 4-1 lists common malfunctions that you may find with your equipment. Perform the tests, inspections and corrective actions in the order they appear in the table.

This table does not list all of the malfunctions that may occur with your device, or all of the tests, inspections, and reparative actions that may be necessary to find and correct the defects. If the equipment malfunction or suggested actions listed fail to correct the problem, contact Armasight's Customer Service Center or your Armasight retailer.

TABLE 4-1. OPERATOR'S TROUBLESHOOTING

MALFUNCTION	PROBABLE CAUSE/TEST/INSPECTION	CORRECTIVE ACTION
1. Goggles fail to activate	Visual. Check for defective, missing or improperly installed battery(ies).	Turn switch to RESET/ OFF position, and then back to ON. Replace the battery(ies) or install them correctly. If PVS-7 still fails to activate, contact Customer Support.
2. IR indicator fails to activate	Visual.	Contact Customer Support.
3. Poor image quality	Check objective lens or eyepiece focus. Check for fogging or dirt on lens.	Refocus. Clean lens surface.
4. Light visible around eyecup	Check eye relief distance. Check eyecup for resiliency.	Readjust for proper eye relief distance. If eyecups are defective, contact Customer Support.
5. Diopter adjustment cannot be made	Check to see if the diopter adjustment ring is bent or broken.	If damaged, contact Customer Support.
6. Interpupillary adjustment cannot be made (left & right eye)	Defective eyepiece assembly.	Contact Customer Support.

TABLE 4-1. CONTINUED

MALFUNCTION	PROBABLE CAUSE/TEST/INSPECTION	CORRECTIVE ACTION
7. Battery cap difficult to turn	Check for dirt or grit in threads. Visually inspect for the presence of an o-ring. Check for damaged battery cap or threads on battery compartment.	Clean the battery cap. If o-ring is missing, contact Customer Support. If damaged, contact Customer Support.
8. PVS-7 does not shut off when removed from head mount during operation	Visual.	Return both the PVS-7 and head mount to your Armasight retailer or Armasight manufacturer for service.
9. Head straps cannot be tightened	Check for defective buckles, fasteners or straps.	If damaged, contact Customer Support.
10. Head mount or helmet mount socket and goggles do not catch	Check socket or latch for dirt. Check socket or latch for damage.	Clean socket and latch. If damaged, return both the head mount or helmet mount and PVS-7 to your Armasight retailer or Armasight manufacturer for service.
11. Helmet mount will not tighten to helmet	Visual.	If damaged, contact Customer Support.
12. IR spot/flood lens will not adjust	Visual.	Contact Customer Support.
13. Compass does not illuminate	Visual.	Contact Customer Support.
14. Compass will not stay on the PVS-7	Visual.	Possibly missing an o-ring. Contact Customer Support.
15. Compass display is not clear	Visual.	Make sure the PVS-7 is focused at infinity. If it is and the compass display is still not clear, contact Customer Support.
16. PVS-7 does not shut off when exposed to high light test under day light or bright room light.	Perform the following tests in day light or bright room light. Place the lens cap on the objective lens. Turn the PVS-7 on and verify that they shut off within 70 (± 30) seconds after energized. Turn the goggles off and then on to re-energize.	If damaged, contact Customer Support.

4.2 IDENTIFICATION OF OPERATIONAL DEFECTS

4.2.1 OPERATIONAL DEFECTS

Operational defects relate to the reliability of the intensifier, and are an indication of instability. If identified, the user will need to return the PVS-7 immediately. Operational defects include shading, edge glow, flashing, flickering, and intermittent operation.

A. Shading

If shading is persistent, you will not be able to see a fully circular image (Figure 4-1). Shading is a very dark, high-contrast area with a distinct line of demarcation present, and you cannot see an image through it. Shading always begins on the edge, and will eventually migrate inward until it spans across the entire image area. If you notice shading with your device, please contact Customer Support.

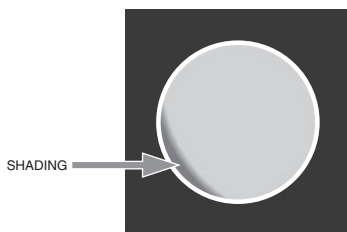

FIGURE 4-1. SHADING

NOTE:

Verify that any shading is not the result of improper eye-relief adjustment.

B. Edge Glow

Edge glow is a bright area (it sometimes appears to be sparkling) in the outer portion of the viewing area (see Figure 4-2). To check for edge glow, block out all light from the device by cupping a hand over the lens. If the image tube is displaying edge glow, the bright area will still show up; if edge glow occurs, please contact Customer Support.

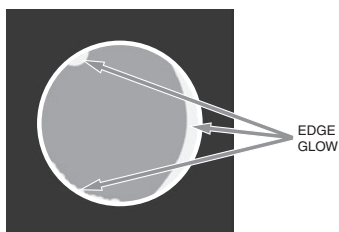

FIGURE 4-2. EDGE GLOW

C. Flashing, Flickering, or Intermittent Operation

The image may appear to flicker or flash. If there is more than a single flicker, check for a loose battery adapter or a weak battery. If flickering continues, please contact Customer Support.

4.2.2 COSMETIC BLEMISHES

Cosmetic blemishes are usually the result of manufacturing imperfections. They **do not** affect the reliability of the image intensifier, and are not normally a cause for returning the PVS-7. However, some types of cosmetic blemishes can worsen over time and interfere with the user's ability to properly operate the device during missions. If you believe a cosmetic blemish is cause for returning the device, record the specific nature of the problem on the maintenance forms and use the clock method to identify the position of the blemish and its approximate distance from the center (e.g., 5:00 toward the outside, 2:30 near the center, or 1:00 midway).

The following are examples of cosmetic blemishes:

A. Bright Spots

A bright spot is a small, non-uniform bright area that may flicker or appear constant (Figure 4-3). Not all bright spots make the PVS-7 returnable. Cup your hand over the lens to block out all light. If the bright spot remains, please contact Customer Support.

Bright spots usually go away when all light is blocked out. Verify that any bright spots are not simply the result of bright light in the area you are observing. Bright spots are acceptable if they do not interfere with the user's ability to view the scene or perform missions.

B. Emission points

Emission points are steady or fluctuating pinpoints of bright light in the image area that do not go away when all external light is blocked from the objective lens (Figure 4-3). The position of an emission point within the image area does not move. Not all emission points are cause to return the PVS-7. Verify that emission points are not simply light sources present in the scene you are observing. Emission points are acceptable if they do not interfere with the user's ability to perform missions.

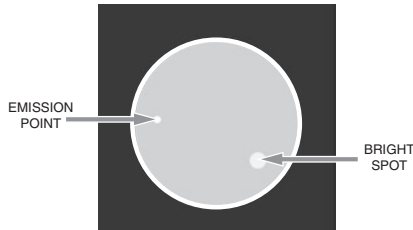

FIGURE 4-3. EMISSION POINTS AND BRIGHT SPOTS

C. Black Spots

Black spots are cosmetic blemishes in the image intensifier or debris between the lenses. Black spots are acceptable as long as they do not interfere with the user's ability to observe the scene. No action is required if this condition is present, unless the spots interfere with the operator's ability to perform missions.

D. Fixed-pattern Noise

Fixed-pattern noise is usually a cosmetic blemish characterized by a faint hexagonal (honeycomb) pattern that appears throughout the viewing area. This typically occurs in excessively lit environments or when viewing very bright lights (See Figure 4-4). This pattern can be seen in every image intensifier if the level of light is high enough. This condition is acceptable as long as the pattern does not interfere with the user's ability to view an image or interfere with their ability to perform missions.

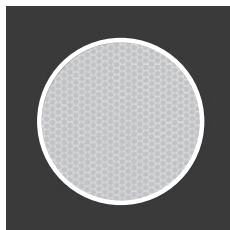

FIGURE 4-4. FIXED-PATTERN NOISE

E. Chicken Wire

Chicken wire is an irregular pattern of dark thin lines that can appear in the field of view, either throughout the image area or in sections of the image area (See Figure 4-5). In the worst-case scenario, these lines will form hexagonal or square, wave-shaped lines. No action is required if this condition is present, unless it interferes with the user's ability to view the image or their ability to perform missions.



FIGURE 4-5. CHICKEN WIRE

4.3 MAINTENANCE

4.3.1 GENERAL

The section regarding PVS-7 operator maintenance consists of operational tests, inspections for unit serviceability, cleaning and mounting procedures, troubleshooting, and replacement instructions for a limited number of parts. Maintenance instructions covered elsewhere in this manual (PMCS, troubleshooting, etc.) are not repeated in this section.

CAUTION:

The PVS-7 is a precision electro-optical instrument and must be handled carefully. Do not scratch the external lens surfaces or touch them with your fingers.

If necessary, clean the goggles with water and dry them thoroughly. Clean lenses with lens paper (and water if necessary, except for demist shields)

CAUTION:

Wiping demist shields with lens paper while wet can damage the coating.

4.3.2. HEAD MOUNT MAINTENANCE

A. Brow Pad Replacement. Replace the brow pad when cracked, torn or contaminated. Perform the following procedure to remove and replace the brow pads.

CAUTION:

For protection of the image intensifier, disconnect the PVS-7 from the head mount prior to replacing brow pads.

1. Firmly grasp the head mount and remove the old brow pad.
 2. Gently press on the new brow pad. Lightly smooth out any wrinkles in the new brow pad.
- B. Neck Pad Reinstallation.** When operating the device, it is possible for the neck pad to become separated from the headband. Perform the following to reinstall the neck pad.
1. Lift the upper headband strap retention tab (see Figure 4-6). This will allow the neck pad strap to be inserted underneath.
 2. Slip the neck pad strap all the way under the upper strap retention tab and then pull the lower part of the neck pad strap under the lower strap retention.

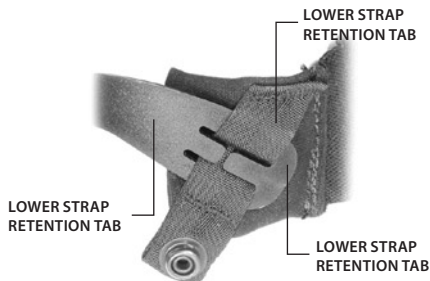

FIGURE 4-6. RE-INSTALLING THE NECK PAD

3. If necessary, repeat steps 1 and 2 for the other side of the headband and neck pad.

C. Lacing the Sliding Bar Buckles. While putting on and adjusting the head mount, it is possible for a strap to slip out of a slide fastener. Perform the following to replace the strap and sliding bar buckle.

1. Thread the strap from the inside of the buckle over the moveable sliding bar (see Figure 4-7). Thread the strap back through the buckle; this time, thread it under the sliding bar and over the serrated part of the buckle.
2. Pull the strap through the buckle and tighten as necessary.
3. Repeat steps 1 and 2 for any other straps and buckles that may have come undone.

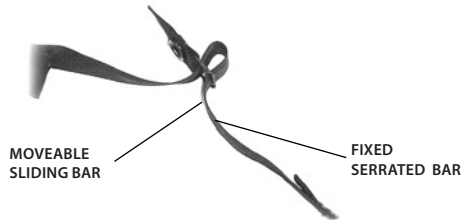

FIGURE 4-7. LACING THE SLIDING BAR BUCKLES

4.4 SERVICE/PACKING AND UNPACKING

4.4.1 RETURN INSTRUCTIONS

For service, repair or replacements, please email service@armasight.com.

To assist the Service Representative (SR) with determining if the item is repairable, please provide the following information:

1. Serial Number of the defective item.
2. Thorough description of the malfunction, defect or damage.
3. An explanation of how the malfunction, defect or damage occurred, if known.

If the SR determines that the item is under warranty or should be returned for repair, a Return Material Authorization number (RMA#) will be provided. RMA can be obtained via e-mail to service@armasight.com or via phone by calling Armasight Customer Service at (888)959-2259 Ext. 2 or via fax (888)959-2260.

When returning the PVS-7 for service or repair, the following procedures should be observed to prevent any additional damage:

1. Verify that the PVS-7 is free of all contaminants, such as dirt or other foreign material.
2. Remove the batteries.
3. Place the cap over the lens.
4. Place the PVS-7 in the hard shipping/ storage case or soft carrying case (if available). If the hard shipping/ storage case is not available, individually package each PVS-7 unit being returned in a suitable container.

Place the PVS-7 and a copy of the test report or detailed description of the failure in a suitable packing/ shipping container. Mark the package with the RMA#. Ship the items using the fastest, most easily traceable, prepaid method to:

Armasight, Inc.
815 Dubuque Avenue
South San Francisco, CA 94080
USA

A. SYSTEM LIST OF SPARE PARTS

The parts authorized in this list of spare parts are required for operator maintenance. This list includes parts that must be removed in order to replace authorized parts.

The PART NO. Column indicates the primary number used by the manufacturer to identify an item; this number controls the design and characteristics of the item by means of its engineering, specifications, standards, and inspection requirements.

TABLE A-1. PVS-7 LIST OF SPARE PARTS

ITEM NO.	DESCRIPTION	PART NO.
1	Battery Cap	PVS7BC
2	O-Ring	PVS7OR
3	Lens Cap	PVS7LC
4	Objective Lens Assembly	PVS7OLA
5	Eyepiece Assembly	PVS7EA
6	Eyecup	PVS7EC
7	Switch Knob	PVS7SK
8	IR Spot/Flood Lens	PVS7IRL
9	Sacrificial Window	PVS7SW
10	Demist Shield	PVS7DS
11	Shoulder Strap Assembly	PVS7SSA
12	Neck Cord	PVS7NC
13	AA Alkaline Batteries	-
14	Head Mount Assembly	PVS7HMA
15	Thin Brow Pad	PVS7TBP
16	Medium Brow Pad	PVS7MBP
17	Large Brow Pad	PVS7LBP
18	Operator's Manual	PVS7OM
19	Carrying Case	PVS7CC
20	Shipping/Storage Case	PVS7SSC

B. PRODUCT WARRANTY REGISTRATION CARD

In order to validate the warranty on your product, Armasight must receive a completed Product Warranty Registration Card for each unit, or the user must complete warranty registration on our website (www.armsight.com). Please complete the included form and immediately mail it to our Service Center (address listed below).

ARMASIGHT PRODUCT WARRANTY REGISTRATION CARD

PRODUCT INFORMATION

Product Name _____ Purchased From _____

Purchase Date _____ Product Serial # _____

CUSTOMER INFORMATION

Name _____

Address _____

City _____ Country _____ Zip _____

Day Phone # _____ Home Phone # _____

E-mail address _____

.....
Customer Signature Required

ALPHABETICAL INDEX

A

Abbreviations 10

B

Battery Installation 19

Black Spots 35

Bright Spots 35

C

Cautions 2

Chicken Wire 36

Cleaning 36

Continuous Operation 13

Cosmetic Blemishes 34

D

Diopter Adjustment 13, 28

E

Edge Glow 34

Emission Points 35

Eye Relief 13, 20

F

Fixed-Pattern Noise 35

Flashing, Flickering, or Intermittent Operation 34

F-number 13

Function Switch 12, 27

G

General Information 7

H

Height 22

I

IR Illumination Range 14

IR Illuminator 2, 12, 29

L

Length 13

M

Magnification 13

Maintenance 31, 36

- Goggle Kit 36

- Preventive 31

Mounting 19

O

Objective Lens Focus 27, 28

Operating Instructions 19

Operational Defects 34

Operator Troubleshooting 33

P

PMCS 31

Preparations for Storage 31

S

Safety Summary 2

Shading 34

Spare Parts 39

System Description 11

W

Warranty Information 8

Weight 12

Width 12



Armasight Inc.

815 Dubuque Avenue,
South San Francisco
CA 94080, USA

Phone: (888)959-2259

Fax: (888)959-2260

Intl Phone/Fax: (650)492-7755

info@armasight.com

CAUTION:

This product contains natural rubber latex which may cause allergic reactions! The FDA has noted an increase in the number of reported deaths that are associated with an apparent sensitivity to natural latex proteins. If you are allergic to latex, it is a good idea to learn which products contain it and strictly avoid exposure to those products.

www.armasight.com